

TDD4B2-U200 relay - 2 pole delay-on and 4 pole instantaneous

Datasheet

TDD4B2-U200 is obsolete from January 1st, 2023

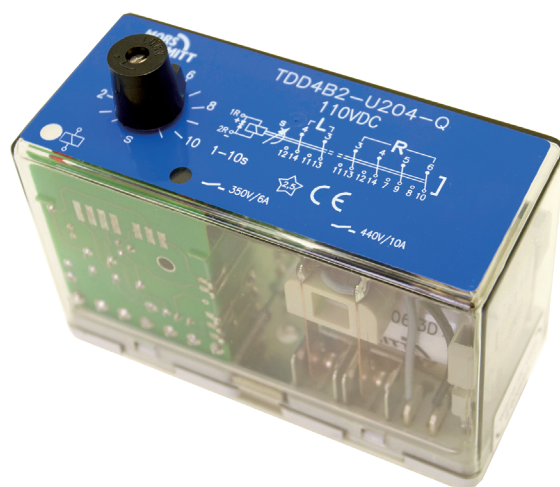

Description

Plug-in electronic railway timer relay with four instantaneous change-over contacts and two time delayed change over contacts. When the relay is activated there is a delay on pull-in for the time delayed contacts. The timer relay has a fixed customer specified delay time, but can also be supplied with an adjustable delay time (with lockable knob). The delayed contacts are weld no transfer contacts. The relay is equipped with two LEDs which indicate the presence of power supply and the energizing of the time delayed contacts.

The construction of the relay and choice of materials makes the TDD4B2-U200 relay suitable to withstand low and high temperatures, shock & vibrating and dry to humid environments.

No external retaining clip needed as integrated 'snap-lock' will hold relay into socket under all circumstances and mounting directions.

Compact design, choice of many options and a wide range of sockets makes the TDD4B2-U200 relay an easy and flexible solution to use.

Application

These relay series are designed for demanding rolling stock applications. The TDD4B2-U200 is used in applications where both instantaneous contacts and time delayed contacts are necessary.

Features

- Time delay and instantaneous relay
- 2 C/O contacts with delay on pull-in and 4 C/O instantaneous contacts
- Fixed time delay (no knob)
- Also available with adjustable time delay with lockable knob
- Total time delay range: 0.1 s...60 min
- Flat, square and silver plated relay pins for excellent socket connection
- Wide range sockets
- Integrated snap lock
- Transparent cover
- Optional positive mechanical keying relay to socket
- Flexibility by many options

Benefits

- Proven reliable
- Long term availability
- Easy to maintain
- Low life cycle cost
- No maintenance

Railway compliancy

- EN 50155 Electronic equipment used on rolling stock for railway applications
- IEC 60571 Electronic equipment used on railway vehicles
- IEC 60077 Electrical equipment for rolling stock in railway applications
- IEC 60947 Low voltage switch gear and control gear
- IEC 61373 Rolling stock equipment - Shock and vibration test
- IEC 60947-5-4 Electromechanical components for control applications. This standard examines both coil and contact specifications in depth
- EN 50121 Electromagnetic compatibility for railway applications
- NF F 16-101/102, EN 45545-2 Fire behaviour - Railway rolling stock
- NF F 62-002 On-off contact relays and fixed connections



TDD4B2-U200 relay

Technical specifications



Functional and connection diagrams

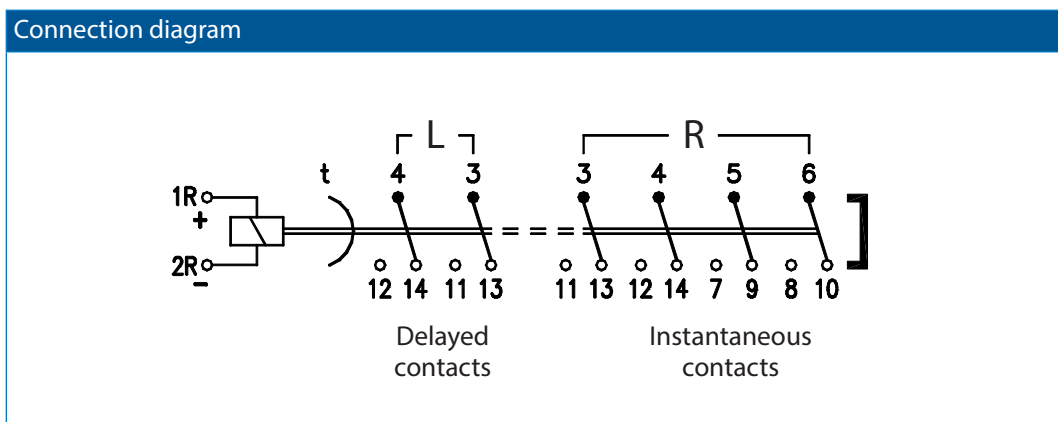
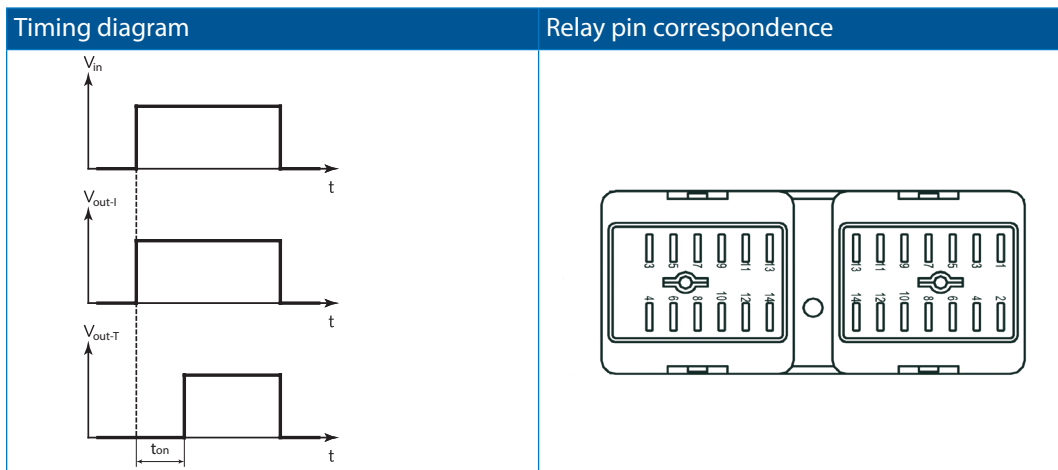

TDD4B2-U200 relay

Technical specifications

Time delay specifications

Time delay function	Delay on pull-in and instantaneous
Available time ranges, adjustable (xx)	0.1...1 s 0.3...3 s 0.6...6 s 1...10 s 3...30 s 6...60 s 0.3...3 min 0.6...6 min 1 ...10 min 3...30 min 6...60 min
Accuracy - adjustment	< 10 % of full scale value After adjusting / fixed time setting: no variation in setpoint
Accuracy - repeatability	± 0.5 %
Time variation - vs. voltage variation	± 0.05 % / % U _{nom}
Time variation - vs. temperature variation	± 0.2 % / K
Recovery time	< 0.2 s
Pull-in time	Instantaneous contacts : < 20 ms Delayed contacts depending on pull-in time setting (xx)
Release time	< 40 ms
Maximum permissible ripple	50 %
<p>Example time delay: time delay set on 2 s : it will be between 1.7 s...2.3 s. For example: 2.0 s. The ambient temperature is 40 degrees Celsius which is 20 degrees different compared to the standard 20 degrees Celsius. This results in 0.4 % extra time variation. The applied voltage is 30 % lower than the nominal voltage. This results in 1.5 % extra time variation. The maximum total time variation is then 0.5 % (repeatability) + 0.4 % (temperature variation) + 1.5 % (voltage variation) = 2.4 %. In this case every new pulse will be between 1.95 s and 2.05 s.</p>	

Coil characteristics

Operating voltage range	0.7...1.25 U _{nom}
Nominal power consumption	< 2.7 W After switching on delayed contacts < 4.2 W

Type	U _{nom} (VDC)	U _{min} (VDC)	U _{max} (VDC)
TDD4B2-U201-xx	24	16.8	30
TDD4B2-U202-xx	48	33.6	60
TDD4B2-U203-xx	72	50.4	90
TDD4B2-U204-xx	110	77.0	137.5
TDD4B2-U205-xx	96	67.2	120
TDD4B2-U207-xx	36	25.2	45

Other types on request

Remarks:

- U_{min} is the must-operate voltage at which the relay has picked up in all circumstances (worst-case situation), in practice the relay picks up at a lower voltage
- Always select the nominal voltage as close as possible to the actual voltage in the application



TDD4B2-U200 relay

Technical specifications

Contact characteristics delayed contacts

Amount and type of contacts	2 C/O
Maximum make current	10 A
Maximum continuous current	8 A (AC1 ; IEC 60947)
Maximum switching voltage	350 VDC, 380 VAC
Minimum switching voltage	12 V
Minimum switching current	10 mA
Maximum breaking capacity	See graph page 7
Contact resistance	15 mΩ (initial)
Material	Ag
Contact gap	1.0 mm
Contact force	> 200 mN

Note: contacts cannot have a different position (forced contacts, Weld-no-transfer)

Contact characteristics instantaneous contacts

Amount and type of contacts	4 C/O
Maximum make current	16 A
Peak inrush current	200 A (withstand > 10 x 200 A @ 10 ms, 1 min)
Maximum continuous current	10 A (AC1 ; IEC 60947)
Maximum switching voltage	250 VDC, 440 VAC
Minimum switching voltage	12 V
Minimum switching current	10 mA
Maximum breaking capacity	110 VDC, 8 A (L/R ≤ 15 ms) 230 VAC, 10 A (cos φ ≥ 0.7)
Contact resistance	15 mΩ (initial)
Material	Ag standard (optional Au on Ag)
Contact gap	0.7 mm
Contact force	> 200 mN

Electrical characteristics

Dielectric strength	EN 50155
Pole-pole	IEC 60255-5 Delayed contacts: 2 kV, 50 Hz, 1 min Instantaneous contacts: 4 kV, 50 Hz, 1 min
Cont-coil	IEC 60077 2 kV, 50 Hz, 1 min
Insulation between open contacts	2.5 kV; 50 Hz; 1 min
EMC	EN 50121-3-2 compliant



TDD4B2-U200 relay

Technical specifications

Mechanical characteristics

Mechanical life	30 x 10 ⁶ operations
Maximum switching frequency	Mechanical: 3600 ops/h Electrical: 1200 ops/h
Maximum torque value screw to lock knob	0.15 Nm
Weight	260 g (without options)

Environmental characteristics

Environmental	EN 50125-1 and IEC 60077-1
Vibration	IEC 61373, Category I, Class B, Body mounted
Shock	IEC 61373, Category I, Class B, Body mounted
Operating temperature	-25 °C...+70 °C (with option C : -40 °C)
Humidity	95 %
Salt mist	IEC 60068-2-11, class ST4
Damp heat	IEC 60068-2-30, Test method Db variant 1
Protection	IEC 60529, IP40 (relay on socket) (with option K : IP50)
Fire & smoke	NF F 16-101, NF F16-102, EN 45545-2
Insulation materials	Cover: polycarbonate Base: polyester



TDD4B2-U200 relay

Technical specifications

Dimensions (mm)

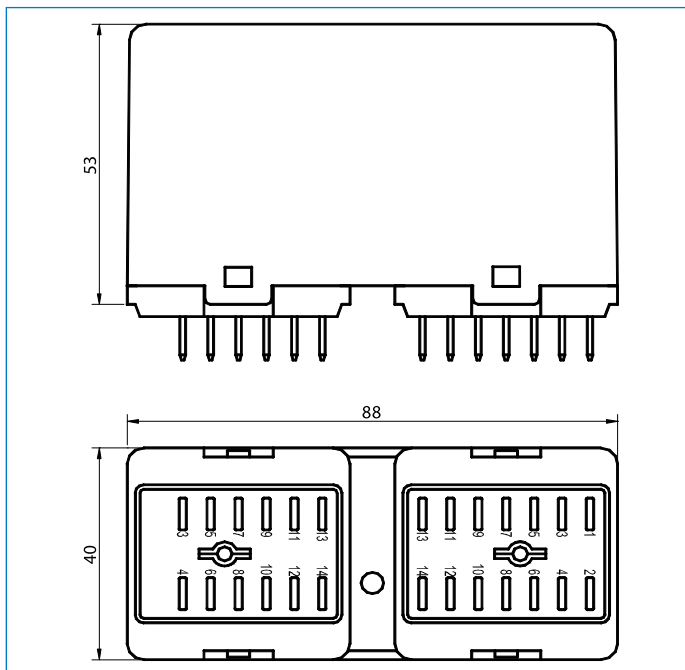

Options

Code	Description	Remark	Cannot be combined with:
C	Low temperature (-40 °C)	Icontact < 8 A	
E*	Au; Gold plated contacts (10 µm)		
K	Dust protection	IP50**	
N	No magnetic arc blow-out		
Q	Double zener diode over coil	Max. allowed peak voltage 180 V, higher voltage will damage the diode	
Keying	Coil coding relay and socket		
Colour coding	Coloured cover for coil voltage coding		

* Gold plated contacts characteristics	
Material	Ag, 10 µm gold plated
Maximum switching voltage	60 V (higher voltages may be possible, contact Mors Smitt for more information)
Maximum switching current	400 mA (at higher rate gold will evaporate, then the standard silver contact rating of minimum 10 mA and 12 V is valid)
Minimum switching voltage	5 V
Minimum switching current	1 mA
** IP50 Cat2 for relays mounted in a Mors Smitt socket, application PD1/PD2 and contact load >0.5A.	



TDD4B2-U200 relay

Technical specifications

Delayed contacts

Switching capacity and contact life

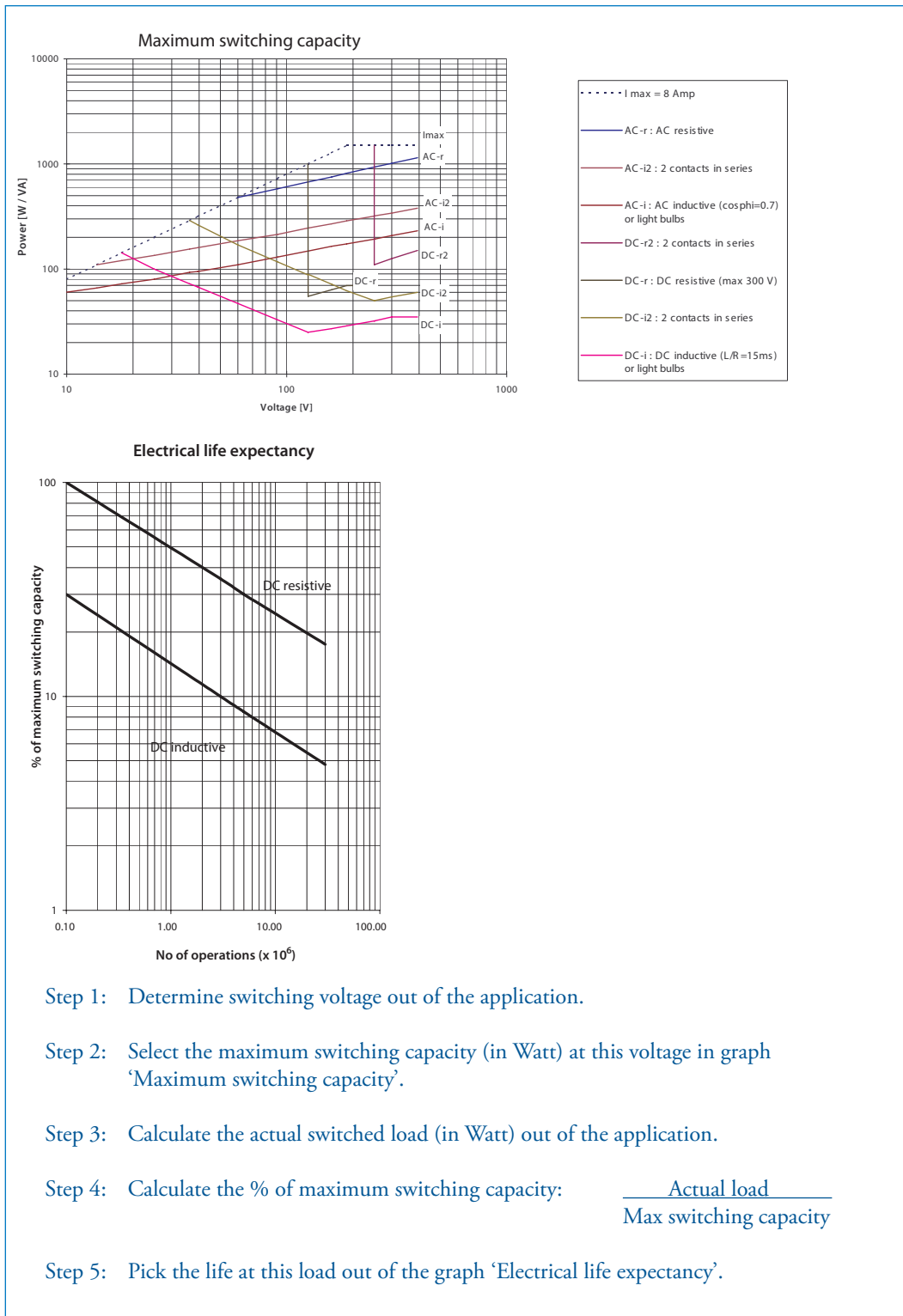

TDD4B2-U200 relay

Technical specifications

Instantaneous contacts

AC Current breaking capacity at $\cos\phi = 1$

AC Current breaking capacity versus life expectancy in millions of cycles.

Rate of contacts opening and closing = 1200 operations per hour.

Curves shown for resistive load (Power Factor = 1).

Curve	1	2	3	4
VAC	220	125	48	24

AC Current breaking capacity

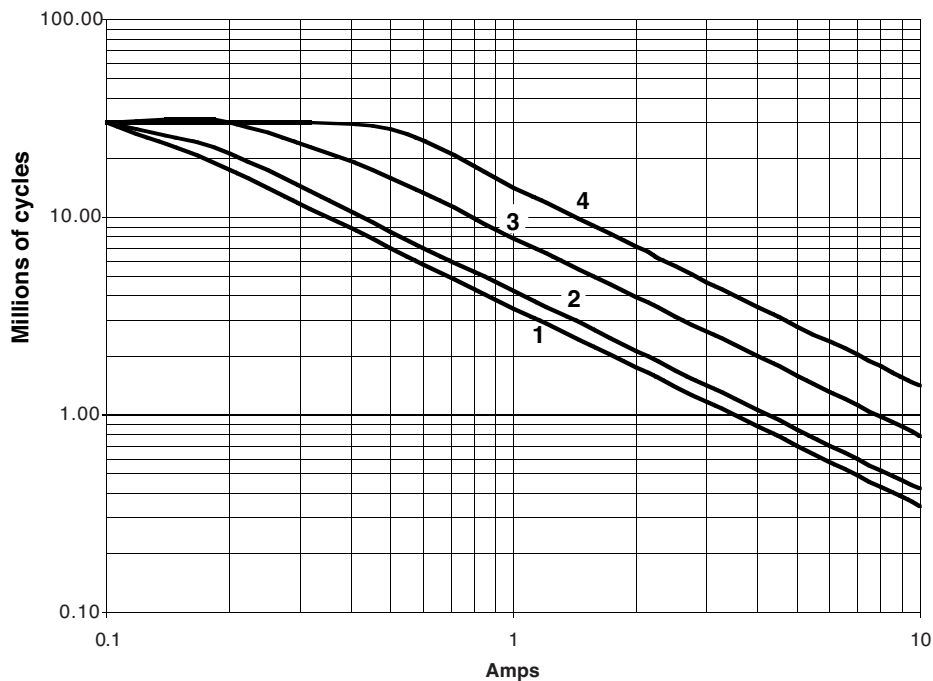

TDD4B2-U200 relay

Technical specifications

Instantaneous contacts

AC Current breaking capacity at $\cos\phi = 0.7; 0.5; 0.3$

AC Current breaking capacity versus life expectancy in millions of cycles.

Rate of contacts opening and closing = 1200 operations per hour.

Values shown for inductive loads -

- $\cos\phi = 0.7$
- $\cos\phi = 0.5$
- - - - $\cos\phi = 0.3$

Curves	1	3	5	6	7	8	9	11	12
VAC	24	24	125	220	24	125	220	125	220
$\cos\phi$	0.7	0.5	0.7	0.7	0.3	0.5	0.5	0.3	0.3

AC Current breaking capacity

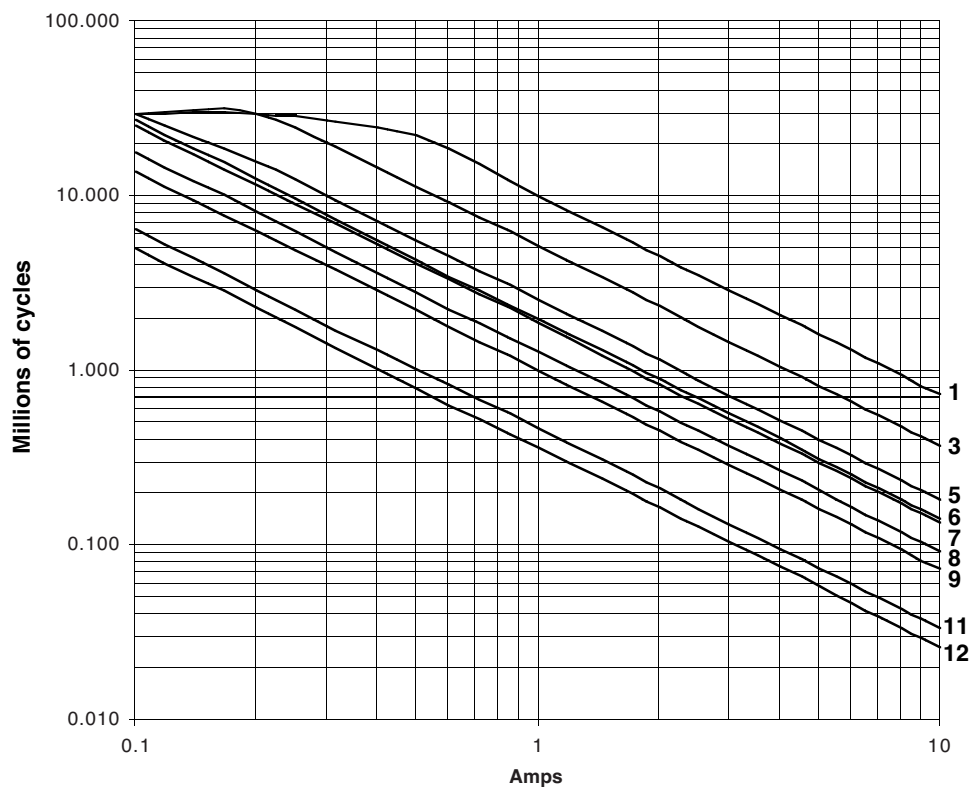

TDD4B2-U200 relay

Technical specifications

Instantaneous contacts

DC Current breaking capacity at $L/R = 0$

DC Current breaking capacity versus life expectancy in millions of cycles.

Rate of contacts opening and closing = 1200 operations per hour.

Curves shown for resistive load ($L/R = 0$). Continuous current.

* By connecting 2 contacts in series, we increase the DC current breaking capacity by 50%

Curve	1	2	3	4
VDC	220	125	48	24

DC Current breaking capacity

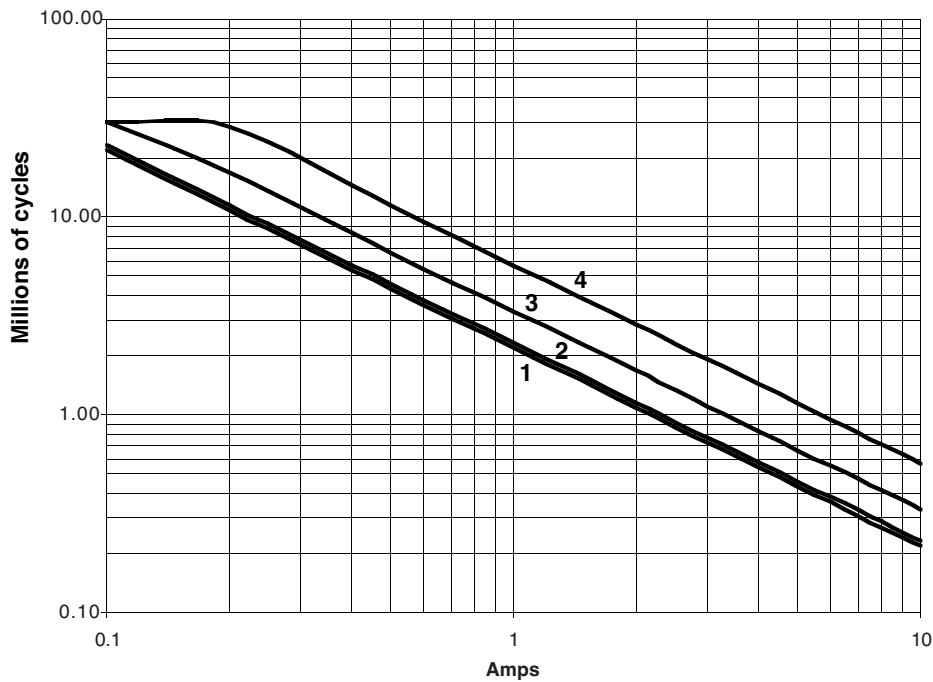

TDD4B2-U200 relay

Technical specifications

Instantaneous contacts

DC Current breaking capacity $L/R = 20\text{ ms}$; 40 ms

DC Current breaking capacity versus life expectancy in millions of cycles.

Rate of contacts opening and closing = 1200 operations per hour.

Curves shown for inductive load -

- L/R = 20 ms continuous current
- - - L/R = 40 ms continuous current

* By connecting 2 contacts in series, we increase the DC current breaking capacity by 50%

Curves	1	2	3	4	5	6	7	8
VDC	24	48	24	125	220	48	125	220
L/R (ms)	20	20	40	20	20	40	40	40

DC Current breaking capacity

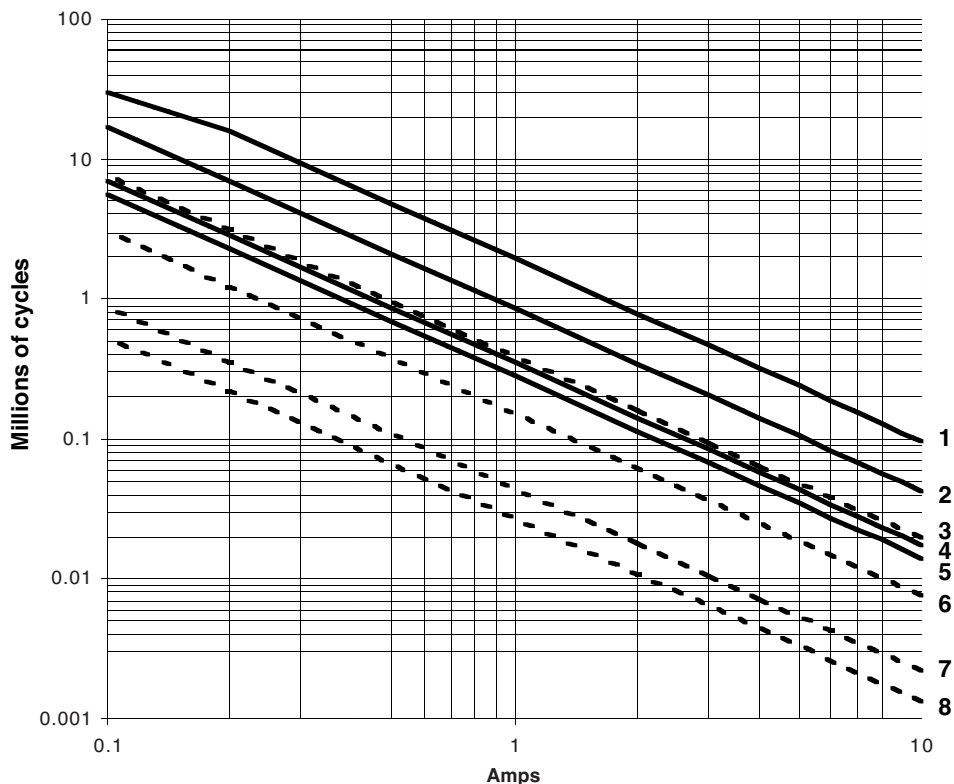

TDD4B2-U200 relay Sockets

Mounting possibilities/sockets

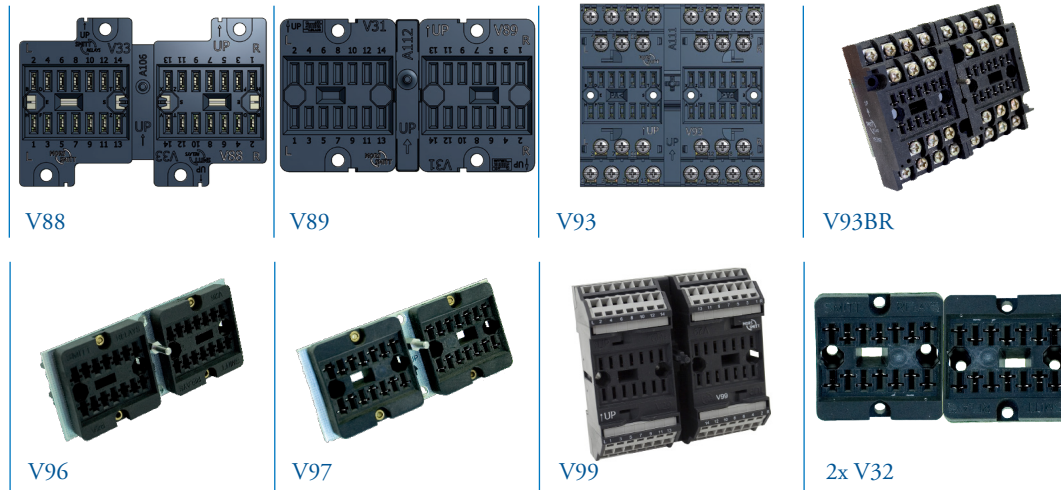

Surface/wall mounting

338002920	V92BR	Screw socket, wall mount, front connection (9 mm terminals)
338003900	V93	Screw socket, wall mount, front connection (7.5 mm terminals)
338003950	V99	Spring clamp socket, wall mount, front dual connection (2.5 mm ²)

Rail mounting

338003900	V93	Screw socket, rail mount, front connection (7.5 mm terminals)
338003925	V93BR	Screw socket, rail mount, front connection (9 mm terminals)
338003950	V99	Spring clamp socket, rail mount, front dual connection (2.5 mm ²)

Panel/flush mounting

338001700	V88	Cage clamp socket, flush mount, rear dual connection (2.5 mm ²)
338001850	V89	Faston connection socket, rear dual connection (4.8 x 0.8 mm)
328100200	V96	Solder tag socket, panel mount, rear connection
338400100	V97	Crimp contact socket, panel mount, rear connection, A260 crimp contact

For PCB mount: use 2x V32 according to pin layout

For more details see datasheets of the sockets



TDD4B2-U200 relay

Keying

Mechanical keying relay and socket (optional)

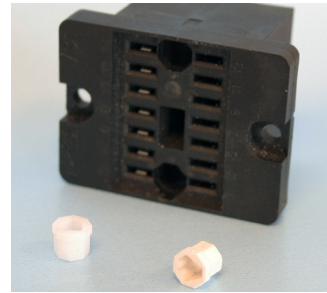
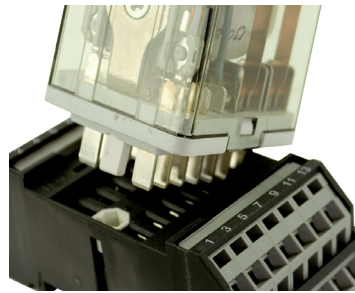

Function:

- To prevent wrong installation
- To prevent damage to equipment
- To prevent unsafe situations

Using keyed relays and sockets prevents a relay is inserted in a wrong socket. For example it prevents that a 24 VDC relay is put in a 110 VDC circuit. Positive discrimination is possible per different function, coil voltage, timing, monitoring, safety and non-safety.

The D-relay socket keying option gives $8 \times 8 = 64$ possibilities. Upon ordering the customer simply indicates the need for the optional keying. Mors Smitt will assign a code to the relay and fix the pins into the relay. The sockets are supplied with loose key receptacles. Inserting the keys into the socket is very simple and self explaining.

Remark: sockets and relay shown are only examples.

Top view socket

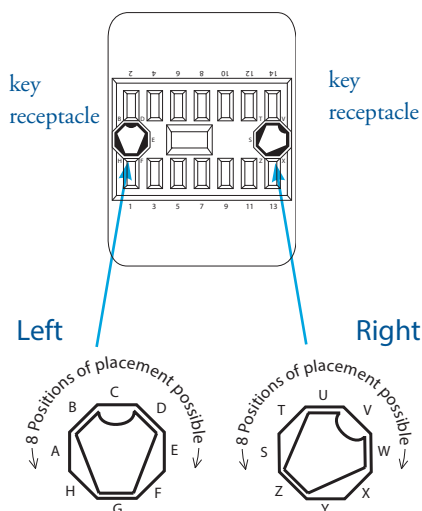

Example keying position G-Z on socket

Bottom view relay

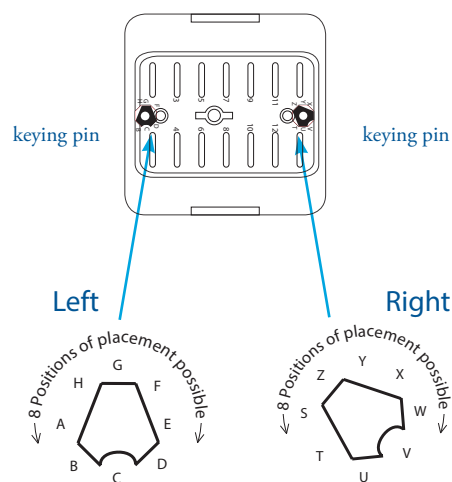

Example keying position G-Z on relay

Remark: for 8 pole relays keying will be in 2 outer keying holes only.



TDD4B2-U200 relay

Instructions

Installation, operation & inspection

Installation

Before installation or working on the relay: disconnect the power supply first! Install socket and connect wiring according to the terminal identification. Plug relay into the socket ensuring there is no gap between the bottom of relay and the socket. Reverse installation into the socket is not possible due to the mechanical blocking snap-lock feature. Check to ensure that the coil connection polarity is not reversed. Relays can be mounted tightly together to save space.

When rail mounting is used, always mount the socket in the direction of the UP arrow, to have proper fixation of the socket on the rail.

Warning!

- Never use silicon in the proximity of the relays.
- Do not use the relay in the presence of flammable gas as the arc generated from switching could cause ignition.
- To remove relays from the socket, employ up and down lever movements. Sideway movement may cause damage to the coil wires.

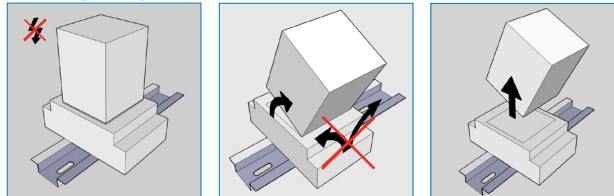

Operation

After installation always apply the rated voltage to the coil to check correct operation.

Long term storage may corrode the silver on the relay pins. When plugging the relay into the socket, the female bifurcated or trifurcated receivers will automatically cut through the corrosion on the pins and guarantee a reliable connection.

Before actual use of relays, switch the relay 10 times. The contacts will both be electrically and mechanically cleaned due to the positive wiping action. Sometimes a contact can build up increased contact resistance (≤ 15 m Ω when new). When using silver contacts one can clean the contact by switching a contact load a few times using >24 VDC & ~ 2 A. Increased contact resistance is not always problematic, as it depends on circuit conditions. In general a contact resistance of 1Ω is no problem, consult Mors Smitt for more information.

Condensation in the relay is possible when the coil is energised (warm) and the outside, environmental temperature is cold. This is a normal phenomenon and will not affect the function of the relay. Materials in the relay have no hygroscopic properties.

Inspection

Correct operation of the relay can easily be checked as the transparent cover provides good visibility of the moving contacts. If the relay does not seem to operate correctly, check for presence of the appropriate coil voltage and polarity using a suitable multimeter. If a LED is fitted, it indicates voltage presence to the coil. If coil voltage is present, but the relay does not operate, a short circuit of the suppression diode is possible (This may be due to the coil connection having been reversed).

If the relay doesn't work after inspection, replace the relay unit with a similar model. Do not attempt to open the relay cover or try to repair. Contacts are calibrated and in balance, touching can affect proper operation. Also re soldering may affect correct operation. Since 2009 relays have tamper proof seals fitted and once broken, warranty is void.

Most relay defects are caused by installation faults such as over voltage, spikes/transients, high/short current far exceeding the relay specifications. When returning the relays for investigation, please provide all information on the RMA form. Send defective relays back to the manufacturer for repair or replacement. Normal wear and tear or external causes are excluded from warranty.



TDD4B2-U200 relay

Ordering scheme

Configuration:



1. Relay model

2. Coil voltage

3. Options

4. Time range

This example represents a **TDD4B2-U204-C 1...10 s**

Description: TDD4B2 - U200 relay, U_{nom}: 110 VDC, low temperature (-40 °C), time range 1...10 s

1. Relay model

TDD4B2 - U2

2. Coil voltage

01	24 VDC
02	48 VDC
03	72 VDC
04	110 VDC
05	96 VDC
07	36 VDC

3. Options

C	Low temp. (-40 °C) - Max. contact current 8 A
E	Gold plated contacts
K	Dust protection, IP 50
N	No magnetic arc blow-out
Q	Double zener diode

4. Time range

0.1...1 s	0.3...3 min
0.3...3 s	0.6...6 min
0.6...6 s	1...10 min
1...10 s	3...30 min
3...30 s	or fixed (no knob)
6...60 s	

Upon ordering indicate keying if necessary.



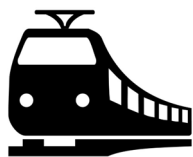

Mors Smitt France SAS

Tour Rosny 2, Avenue du Général de Gaulle,
F - 93118 Rosny-sous-Bois Cedex, FRANCE
T +33 (0)1 4812 1440, F +33 (0)1 4855 9001
E sales.msf@wabtec.com

Mors Smitt Asia Ltd.

29/F, Fun Towers, 35 Hung To Road
Kwun Tong, Kowloon, HONG KONG SAR
T +852 2343 5555, F +852 2343 6555
E sales.msa@wabtec.com

Mors Smitt B.V.

Vrieslantlaan 6, 3526 AA Utrecht,
NETHERLANDS
T +31 (0)30 288 1311, F +31 (0)30 289 8816
E sales.msbv@wabtec.com

Mors Smitt Technologies Inc.

1010 Johnson Drive,
Buffalo Grove, IL 60089-6918, USA
T +1 847 777 6497, F +1 847 520 2222
E salesmst@wabtec.com

Mors Smitt UK Ltd.

Graycar Business Park, Barton under Needwood,
Burton on Trent, Staffordshire, DE13 8EN, UK
T +44 (0)1283 722650 F +44 (0)1283 722651
E sales.msuk@wabtec.com

RMS Mors Smitt

6 Anzed Court, Mulgrave,
VIC 3170, AUSTRALIA
T +61 (0)3 8544 1200 F +61 (0)3 8544 1201
E sales.rms@wabtec.com