

MSA200 - Hall effect transducer

Datasheet



Description

The transducers are based on compensating the magnetic field by a closed loop system. The MSA200 is used for the measurement of AC and DC currents with high galvanic isolation between the current carrying conductor and output of the sensor. The current transducer can handle pulsed currents. The MSA200 transducers are especially designed for secure measuring of a permanent current up to 200 A. The current measuring range covers a bandwidth from -400 A to 400 A.

Application

The Mors Smitt transducers are used to measure high currents in rolling stock and track side applications. High currents are converted linear to low power signals.

Features

- Specially designed for railway applications
- Closed loop (compensated)
- High dielectric strength
- Precise linearity
- Precise accuracy
- High dynamic response
- No Foucault losses in the magnetic circuit
- EMC shielding (optional)
- Wide temperature range, -50°C..+85°C

Benefits

- Proven reliable
- Long term availability
- Low life cycle cost
- No maintenance

Railway compliancy

- EN 50155 - Railway application electronic equipment used in rolling stock
- IEC 61373 - Rolling stock equipment - Shock and vibration test
- NF F16-101/102 - Fire behaviour - Railway rolling stock
- IEC 60068-2-11 - Environmental testing: Salt mist - Test ka - 96 hours



MSA200

Technical specifications



Connection diagram

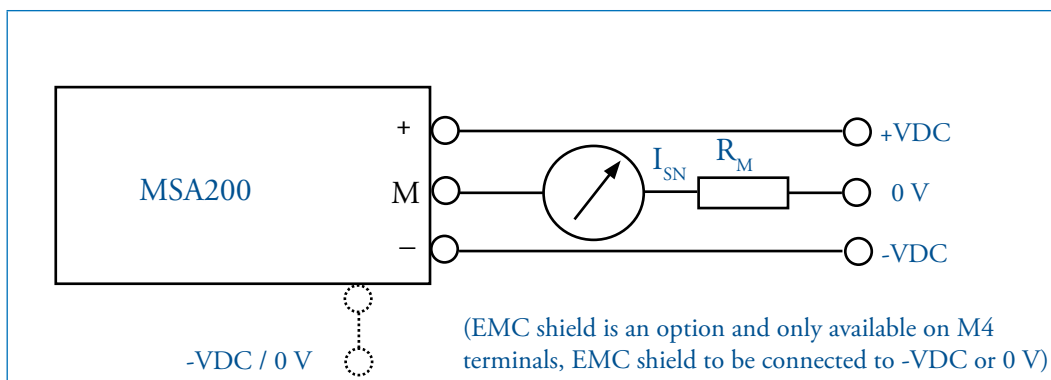

MSA200

Technical specifications

Electrical characteristics

Primary nominal r.m.s. current	I_{PN}	200 A
Primary current measuring range	I_P	± 400 A
Secondary nominal r.m.s. current	I_{SN}	100 mA / 67 mA ($I_{SN} = I_{PN} / K_N$)*
Conversion ratio	K_N	1:2000 / 1:3000 *
Secondary coil resistance @ 70 °C	R_S	25 Ω @ $K_N=1:2000$ / 56 Ω @ $K_N=1:3000$ *
Auxiliary supply voltage	V_N	± 12 VDC to ± 18 VDC $\pm 5\%$
Current consumption	I_C	± 24 mA + I_S @ 18 VDC (I_S = secondary current)
Dielectric strength	V_D	3 kV / 6 kV (50 Hz - 1 min) *
Output measuring resistance	R_M	$R_M = ((V_{NC} - dV) / I_{SN}) - R_S$ (see explanation below)

* See ordering scheme

Legend:

dV = Fixed value = 1.6 V
 V_N = Nominal auxiliary supply
 V_{NC} = Lower value of the auxiliary supply
 ($V_N - 5\%$ typical)
 R_S = Secondary coil resistance at 70 °C
 I_{SN} = Secondary current

Example:

dV = 1.6 V
 V_N = 15 V
 V_{NC} = 14.25 V
 I_{PN} = 200 A
 K_N = 2000 turns
 R_S = 25 Ω
 I_{SN} = I_{PN} / K_N
 I_{SN} = 200 / 2000 = 0.1 A
 R_M = $((14.25 - 1.6) / 0.1) - 25$ = 101.5 Ω

Accuracy / dynamic performance

Overall accuracy @ $I_{PN} - T_A=25$ °C	X_G	$\pm 0.5\% / \pm 1\%$ *
Linearity	ϵ_L	< 0.1%
Offset current @ $I_P=0 - T_A=25$ °C	I_0	± 0.25 mA max.
Thermal drift of I_0 between (-40 °C...+70 °C)	I_{0T}	± 0.4 mA max.
Resp. time @ 90% of I_{PN} and di/dt 100 A/ μ s	T_R	< 1 μ s
Di / dt accuracy followed	di/dt	> 50 A / μ s
Frequency bandwidth (-3 dB)	f	DC to 100 KHz

* See ordering scheme

General characteristics

Operating temperature *	T_A	-50 °C...+85 °C
Storing temperature *	T_S	-50 °C...+85 °C
Weight	m	140 g $\pm 10\%$ (without busbar) 240 g $\pm 10\%$ (with busbar 125 x 20 x 5 mm)
Connection *		Faston 6.35 mm / M4 terminals / Flying leads

* See ordering scheme



MSA200

Technical specifications

Dimensions (mm)

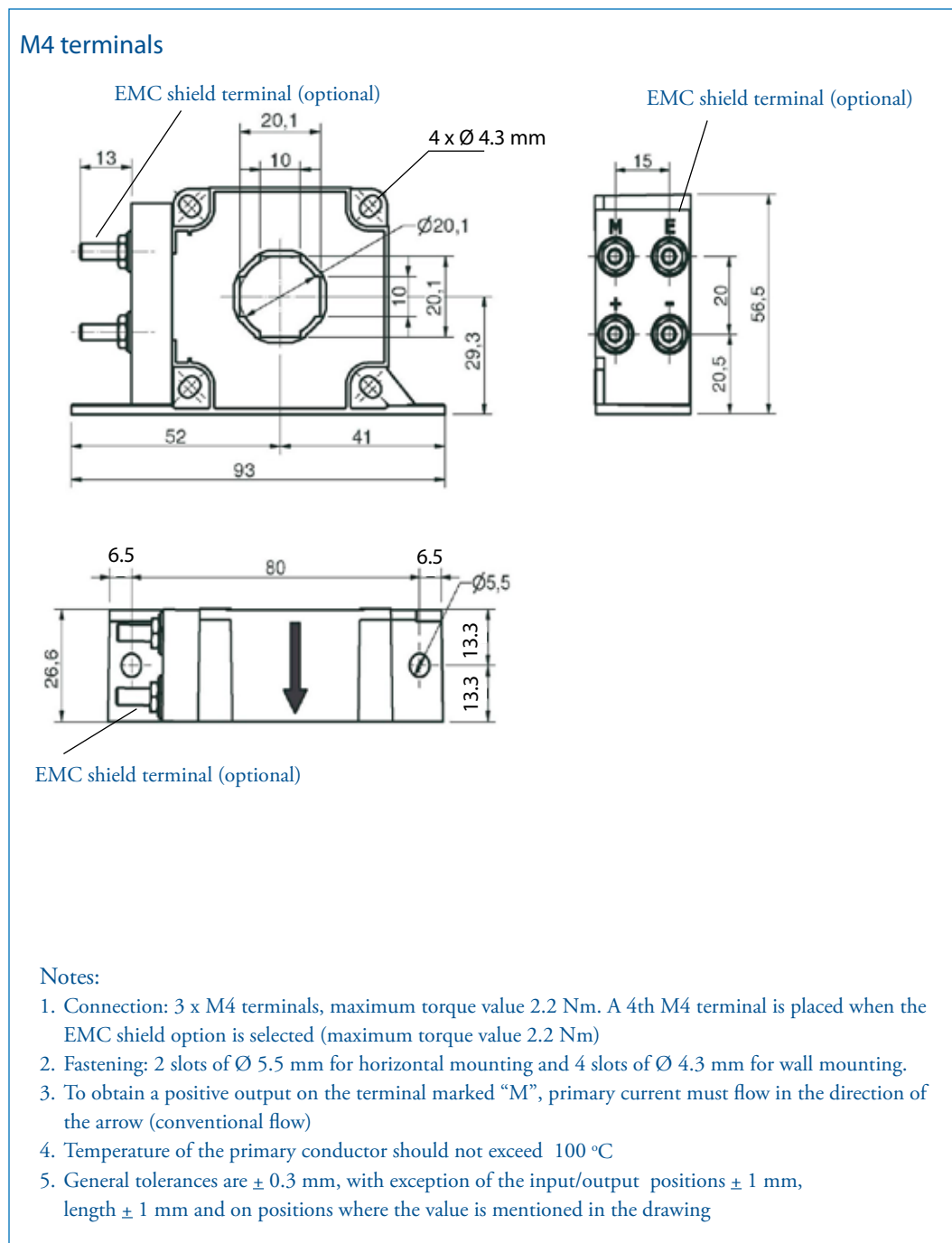

MSA200

Technical specifications

Dimensions (mm)

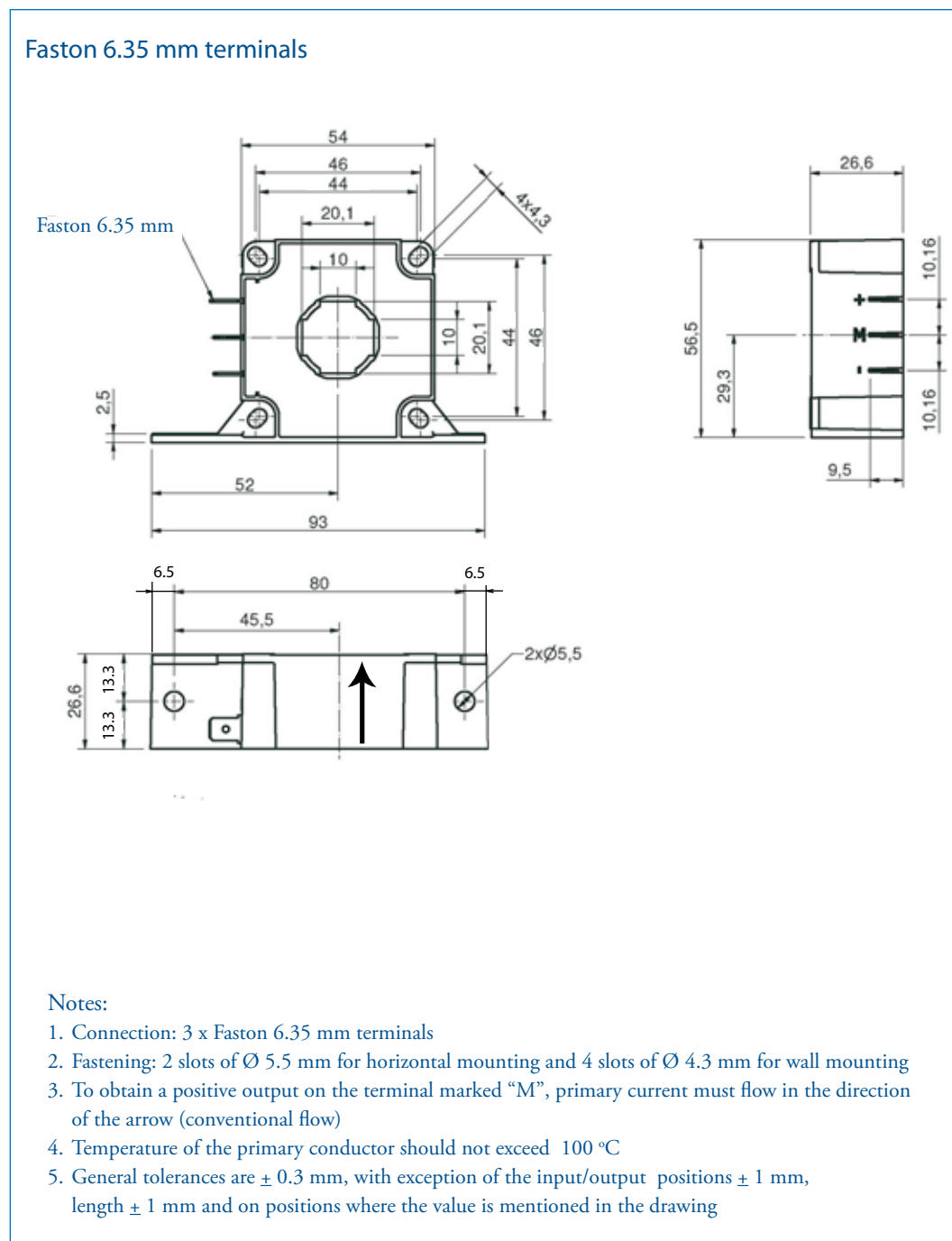

MSA200

Technical specifications

Dimensions (mm)

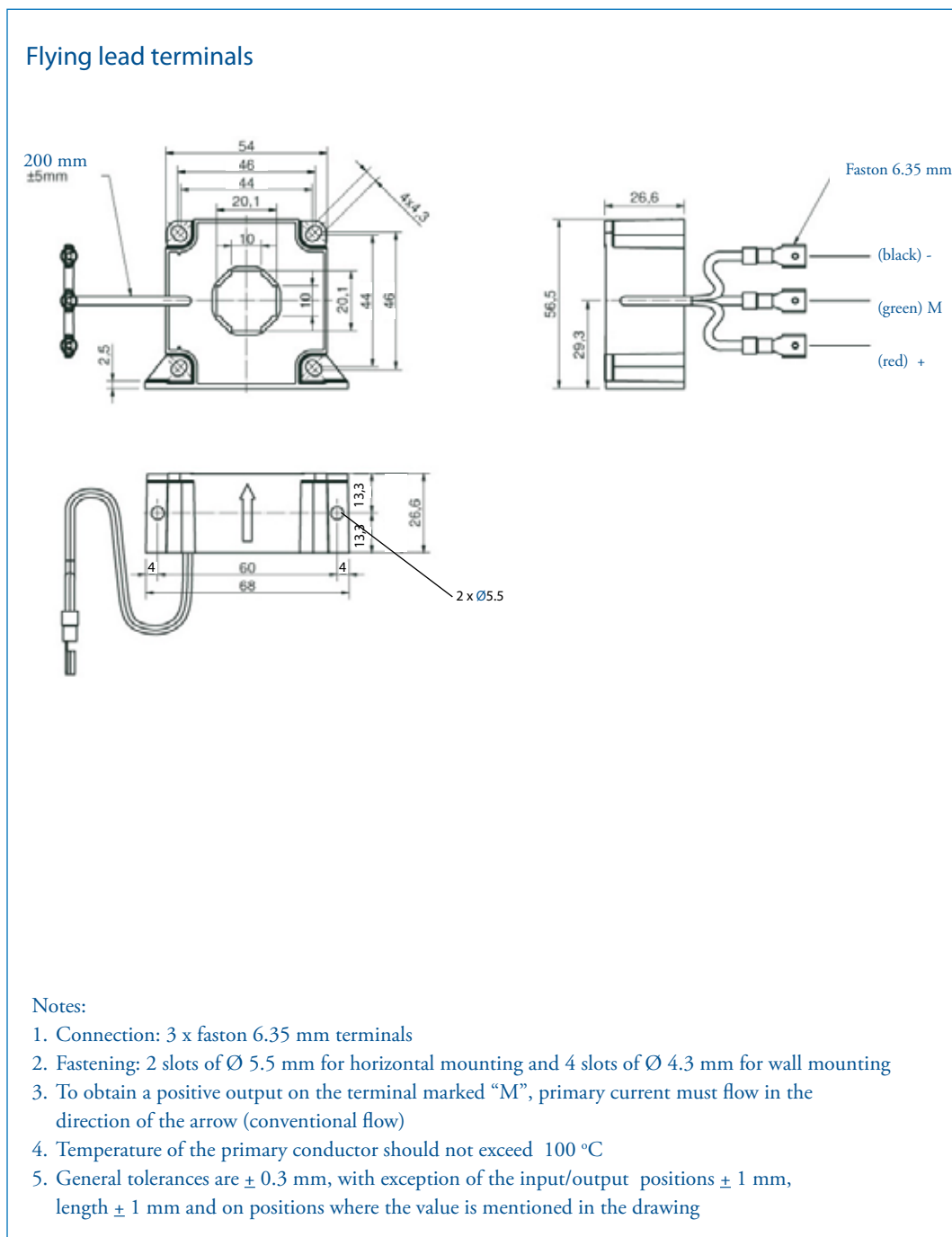

MSA200

Technical specifications

Dimensions (mm)

Mounting with primary bus bar

(Applicable for all terminal types, drawing shows the combination with faston 6.35 mm terminals)

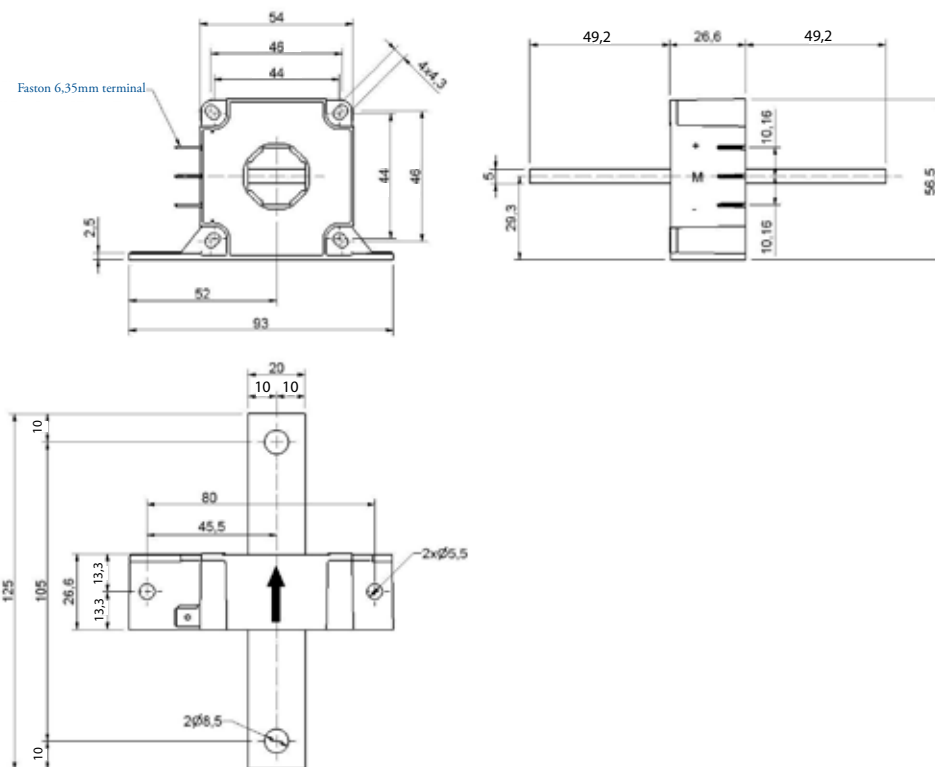

Notes:

1. Connection: 3 x faston 6.35 mm terminals
2. Busbar connections 2 slots of $\text{Ø} 8.5$ mm
3. Fastening: 2 slots of $\text{Ø} 5.5$ mm for horizontal mounting and 4 slots of $\text{Ø} 4.3$ mm for wall mounting
4. To obtain a positive output on the terminal marked "M", primary current must flow in the direction of the arrow (conventional flow)
5. Temperature of the primary conductor should not exceed 100 °C
6. General tolerances are ± 0.3 mm, with exception of the input/output positions ± 1 mm, length ± 1 mm and on positions where the value is mentioned in the drawing
7. The copper busbar weights $90\text{ g} \pm 10\%$
8. Installation with a primary busbar: the sensor must be mechanically fixed only by the bar but not both bar and housing at the same time (this type of fixing would lead to mechanical stress that could lead to breaking of the sensor).



MSA200

Notes



MSA200

Ordering scheme

Configuration:



1. 2. 3. 4. 5. 6. 7. 8.

This example represents a **MSA200-S-2-A-1-2-4-Y**.

Description: MSA200 transducer, with hole for the primary, conversion ratio 1:2000, M4 terminals, dielectric strength 3 kV, 0.5% accuracy, -50 °C...+85 °C temperature range, with EMC shield.

1. Transducer model

MSA200

2. Mounting

S	With hole for the primary
T	With primary busbar

5. Dielectric strength

1	3 kV
2	6 kV

3. Conversion ratio

2	1:2000
3	1:3000

6. Accuracy

1	1 %
2	0.5 %

4. Secondary connection

A	M4 terminals
B	6.35 mm faston
C	Flying lead terminals

A B C

7. Temperature range

4	-50°C...+85 °C
----------	----------------

8. EMC shield *

N	Without EMC shield
Y	With EMC shield

* EMC shield is only applicable on M4 terminals, EMC shield in combination with other terminals on request





www.morssmitt.com



Mors Smitt France SAS

Tour Rosny 2, Avenue du Général de Gaulle,

F - 93118 Rosny-sous-Bois Cedex, FRANCE

T +33 (0)1 4812 1440, F +33 (0)1 4855 9001

E sales@msrelais.com

Mors Smitt Asia Ltd.

807, Billion Trade Centre, 31 Hung To Road

Kwun Tong, Kowloon, HONG KONG SAR

T +852 2343 5555, F +852 2343 6555

E info@morssmitt.hk

Mors Smitt B.V.

Vrieslantlaan 6, 3526 AA Utrecht,

NETHERLANDS

T +31 (0)30 288 1311, F +31 (0)30 289 8816

E sales@nieaf-smitt.nl

Mors Smitt Technologies Inc.

420 Sackett Point Road

North Haven, CT 06473, USA

T +1 (203) 287 8858, F +1 (888) 287 8852

E mstechnologies@msrelais.com

Mors Smitt UK Ltd.

Doulton Road, Cradley Heath

West Midlands, B64 5QB, UK

T +44 (0)1384 567 755, F +44 (0)1384 567 710

E info@morssmitt.co.uk