

# AG 400 relay - Gold plated, 4 contacts

## Datasheet

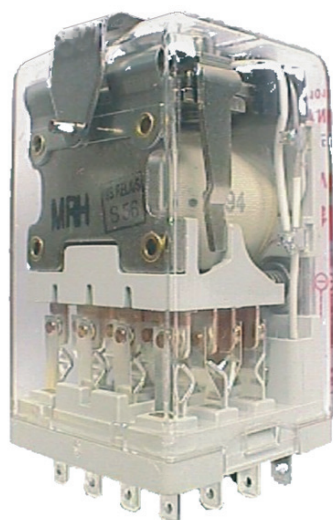

### Description

The AG 400 relay has 4 double make / double break C/O contacts (form Z). The contacts are gold plated on hard silver. This relay is used when dry circuits route to socket are not identified.

The plug-in design offers secure locking feature for maximum ease of maintenance (no wires need to be disconnected or other hardware removed for relay inspection or replacement). The resistance to impact and vibration is conform to standards in force for Railway Transported Equipment.

Positive mechanical keying of relay to socket is built into relay and socket during manufacture and terminal identifications are clearly marked on identification plate that is permanently attached to the relay.

The AG 400 relays is pluggable in the following sockets: EA 102 A, EA 102 AF, EA 103 AF, EA 104 A, EA 104 AF, EA 105 AF, EA 112 AF.

### Application

The AG 400 relay is designed for low level signals switching in dry circuit signal information. The relay is equipped with a contact pollution barrier in case of mixed load operation.

### Features

- Instantaneous relay
- Plug-in design with secure locking feature for maximum ease of maintenance
- 4 double make / double break C/O contacts (form Z), gold plated on silver
- Contact life (mechanical) of 100 million cycles
- -40 °C...+80 °C operating temperature
- Contacts cross pollution barrier
- Optional weld no transfer function

### Benefits

- Proven reliable
- Long life cycle
- Easy to maintain and replace
- Low life cycle cost
- No maintenance

### Railway compliancy

- NF F 62-002 Rolling stock - Instantaneous relays contacts and sockets
- NF F16-101/102 Fire behaviour - Railway rolling stock



# AG 400 relay

## Technical specifications

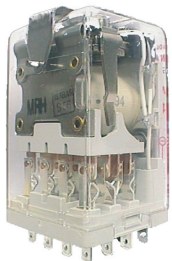

### Functional and connection diagrams

Timing diagram	Relay pin correspondence
	<p><b>Relay pin correspondence</b></p> <p>Example: BG keying</p> <p>N.B.: Transil not needed on VAC coil relays</p> <p><b>Led (V) option</b> (respect polarity)</p>

### Connection diagram

**VDC Models**  
(no Transil protection)

**VDC Models**  
(with Transil protection)

**VAC Models**  
N.B.: Transil not needed on VAC coil relays.



# AG 400 relay

## Technical specifications

### Coil data - DC versions

Keying	Unom (VDC)	Uoperating (VDC)	Pnom (W)	Uhold (VDC)	Udrop-out (VDC)	R coil ( $\Omega$ ) <sup>(1)</sup>	L/R (ms) <sup>(2)</sup>
AG	24	16 / 33	3	13.5	2.5	185	30
FL	36	25 / 45	3	21	3.5	430	30
DG	48	33 / 60	3	28.5	4.5	750	30
BG	72	48 / 90	3	40.5	6.5	1700	30
SV	110	75 / 138	3	62	10	4000	30
EG	125	88/156	3	73	12	5700	30

(1) Coil resistance tol.:  $\pm 8\%$  at 20 °C

(2) Valid for closed relay.

### Coil data - AC versions

Keying	Unom (VAC)	Uoperating (VAC)	Pnom (VA)	Uhold (VAC)	Udrop-out (VAC)	R coil ( $\Omega$ ) <sup>(1)</sup>	L/R (ms) <sup>(2)</sup>
SZ	115	80/140	3	65	10	4000	30
CG	220	176/242	3	129	21	15000	30

(1) Coil resistance tol.:  $\pm 8\%$  at 20 °C

(2) Valid for closed relay.

### Contact data - dry circuit application (gold contacts)

Contact configuration	4 C/O double break contact	
Contact design	Stationary contacts	2 single contacts (contacts are in series)
	Movable contacts	solid blade
Contact resistance	$\leq 20 \text{ m}\Omega$ at 5 A (carry only)	
Maximum contact ratings	Operating	20 mA maximum at 72 VDC
	Carry only (no make and break)	5 A maximum at 5 VDC
Minimum current ratings	10 mA at 12 VDC	
Contact material	Stationary contacts	Gold plated over hard silver
	Movable contacts	Gold over hard silver overlay laminated to copper



# AG 400 relay

## Technical specifications

### Contact design

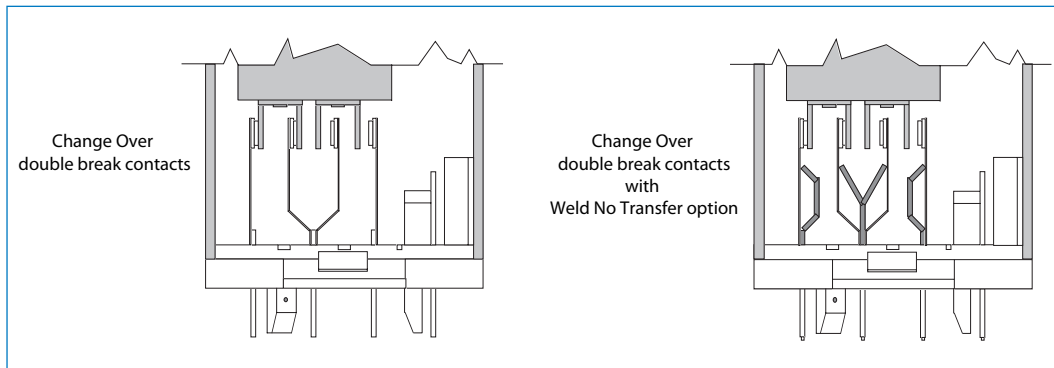

### Electrical characteristics

Dielectric strength	2000 VAC, 1 min between contacts 2600 VAC, 1 min between contacts, coil and frame
Insulation resistance	≥ 1000 MΩ at 500 VDC

### Mechanical & environmental characteristics

Vibration	NF F 62-002 The tests are conducted in the X, Y, Z planes at frequency between 10 & 150 cycles (sinusoidal) at 2 g
Shock	NF F 62-002 Tests are applied in both directions in the X, Y & Z planes. Then successive shocks are administered consisting of the positive component of sinusoidal with a value of 30 g, 18 ms Other vibration and shock tests can be performed on request
Mechanical life	> 100 x 10 <sup>6</sup> operations
Weight	300 g
Temperature	-40 °C...+80 °C
Humidity	93% RH, 40° C for 4 days
Salt mist	5% NaCl, 35° C for 4 days
Protection	IP40 (relay on socket)
Fire & smoke	Materials: Polycarbonate (cover) / polyester melamine (base) Note: These materials have been tested for fire propagation and smoke emission according standards NF F 16-101, NF F 16-102.



# AG 400 relay

## Technical specifications

### Dimensions (mm)

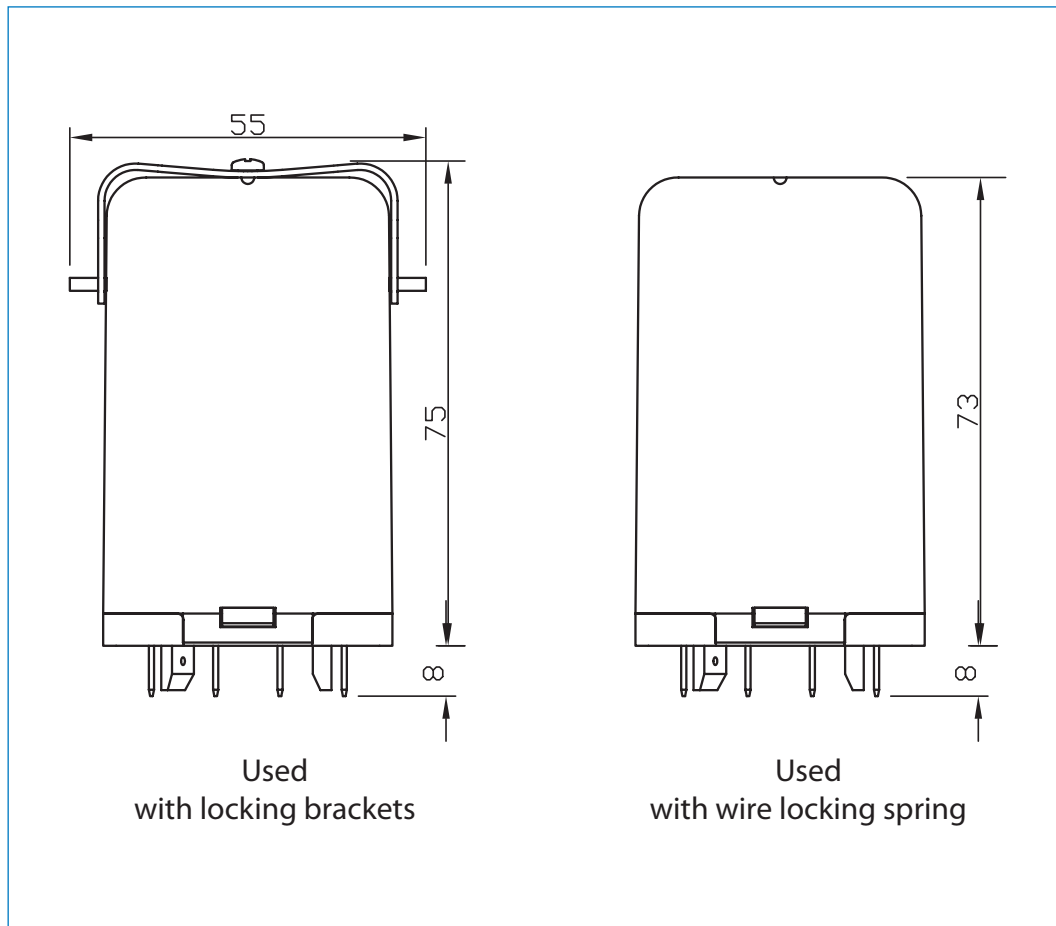

# AG 400 relay

## Technical specifications

### Dynamic relay selection curve No 1

AC Current breaking capacity versus life expectancy in millions of cycles.

Rate of contacts opening and closing = 1200 operations per hour.

Curves shown for resistive load (Power Factor = 1).

Curve	1	2	3	4
VAC	220	125	48	24

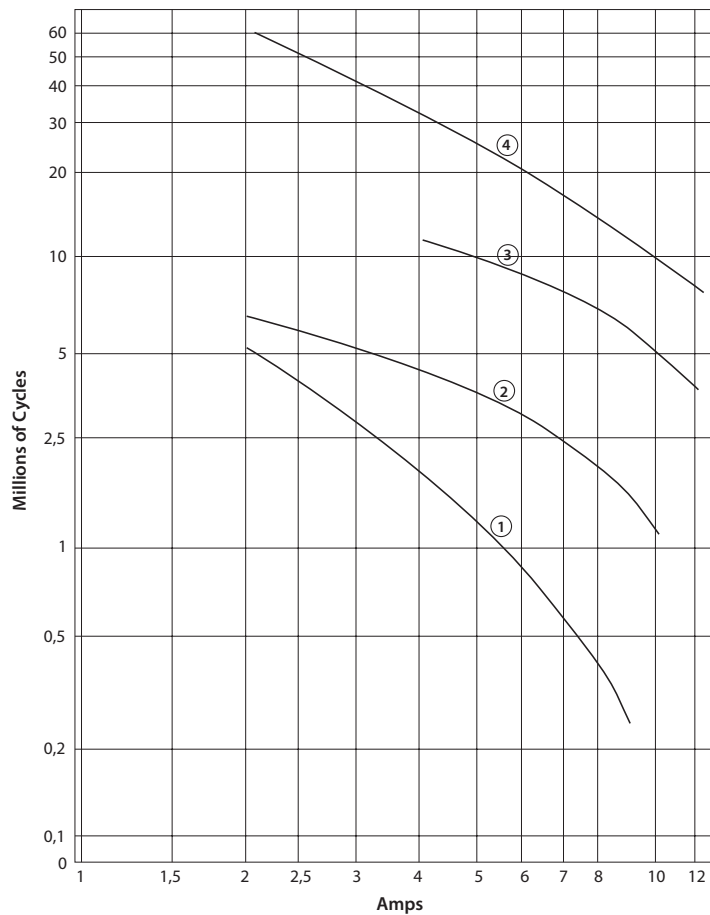

(for specific power contacts on customer circuitry only, not interchangeable into another socket with different customer circuitry configuration)



# AG 400 relay

## Technical specifications

### Dynamic relay selection curve No 2

**DC Current breaking capacity versus life expectancy in millions of cycles.**

Rate of contacts opening and closing = 1200 operations per hour.

Curves shown for inductive load:

- L/R= 20 ms continuous current
- - - L/R= 40 ms continuous current

\* By connecting 2 contacts in series, DC current breaking capacity increases by 50 %

Curves	1-3	2-4	5-6	7-8
VDC	220	125	48	24

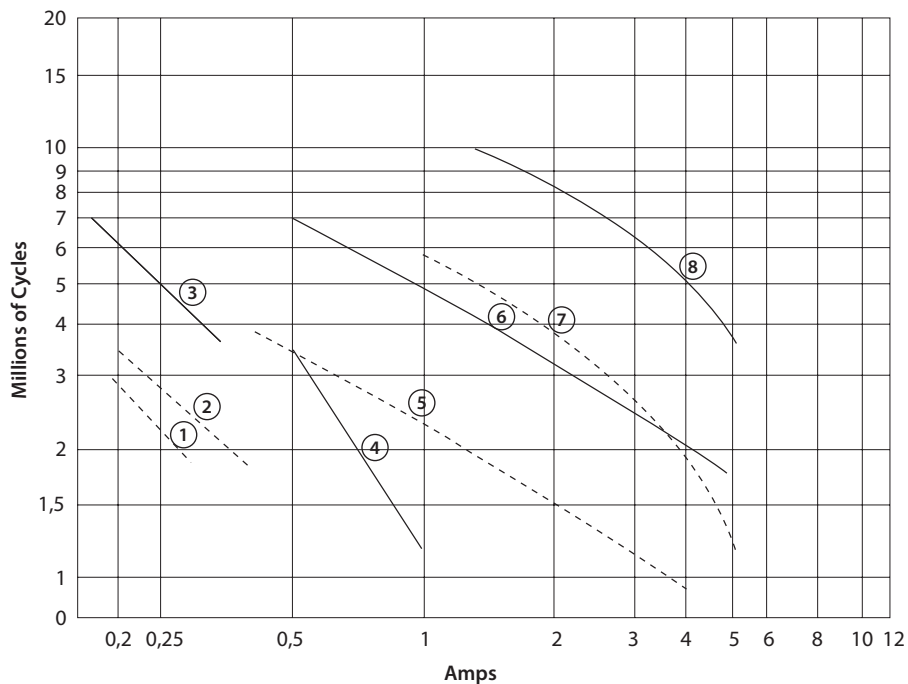

(for specific power contacts on customer circuitry only, not interchangeable into another socket with different customer circuitry configuration)



# AG 400 relay

## Technical specifications

### Dynamic relay selection curve No 3

**DC Current breaking capacity versus life expectancy in millions of cycles.**

Rate of contacts opening and closing = 1200 operations per hour.  
Curves shown for resistive load (L/R = 0). Continuous current.

\* By connecting 2 contacts in series, DC current breaking capacity increases by 50 %

Curve	1	2	3	4
VDC	220	125	48	24

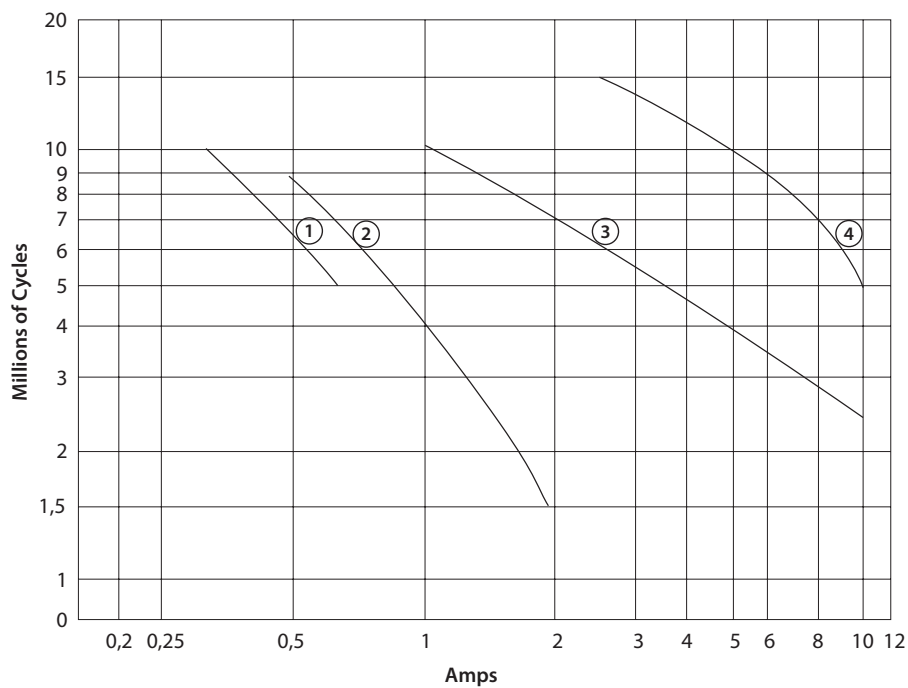

(for specific power contacts on customer circuitry only, not interchangeable into another socket with different customer circuitry configuration)





# AG 400 relay

## Technical specifications

### Dynamic relay selection curve No 4

**Maximum contact breaking capacity versus voltage for a given L/R.**

Rate of contacts opening and closing = 600 operations per hour.

Curves shown for resistive load (L/R=0) and inductive loads. Continuous current.

Life expectancy: 2 Millions of Cycles

Curve	1	2	3	4	5	6
L/R=	0ms	15ms	20ms	40ms	60ms	100ms

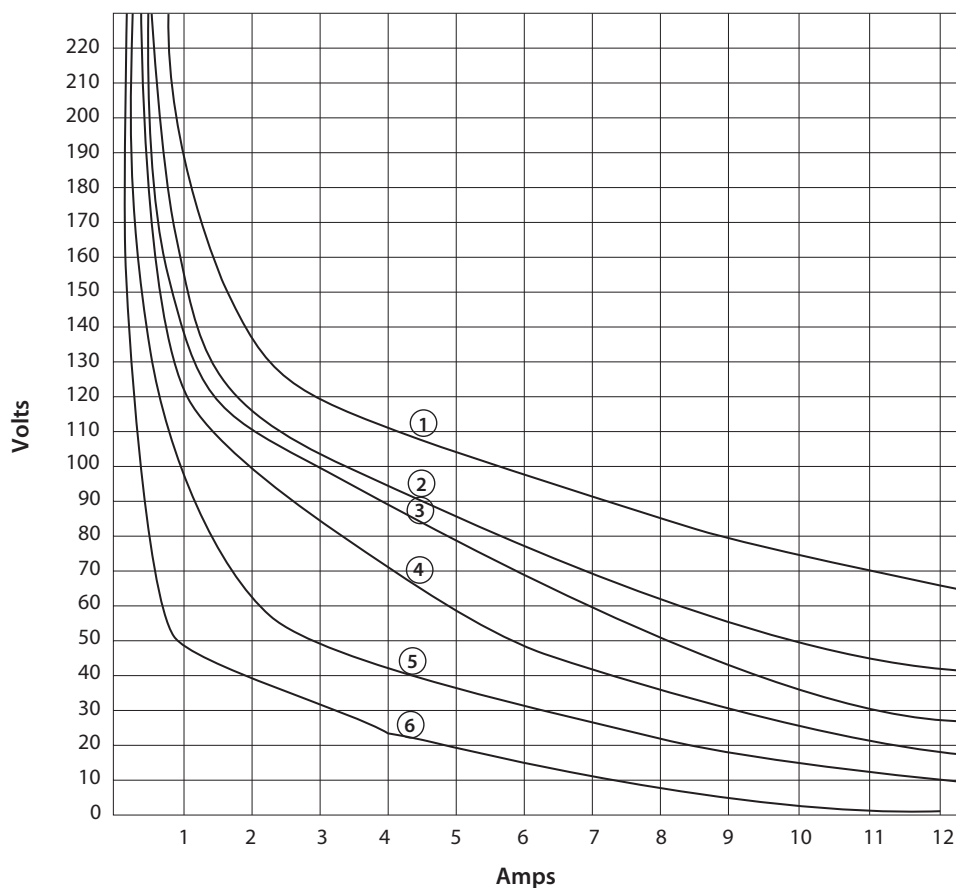

(for specific power contacts on customer circuitry only, not interchangeable into another socket with different customer circuitry configuration)



# AG 400 relay

## Technical specifications

### Dynamic relay selection curve No 5

Maximum power interruption versus load time constant (L/R) for a given voltage.  
Curves shown for resistive loads.  $I = P/V$ .

Curve	1	2	3	4	5
VDC	220	125	72	48	24

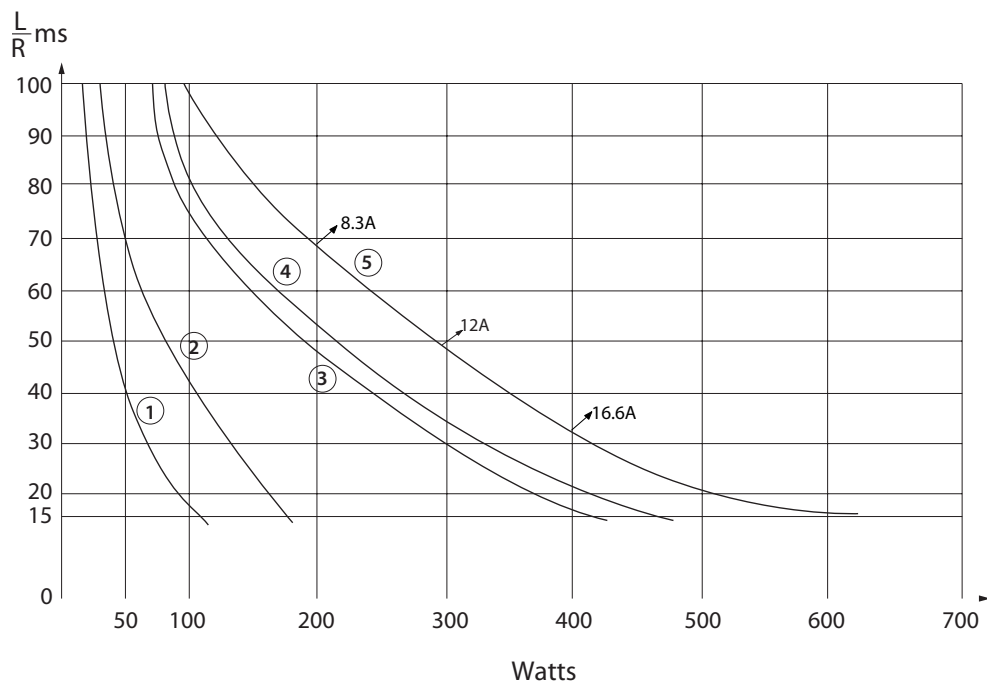

(for specific power contacts on customer circuitry only, not interchangeable into another socket with different customer circuitry configuration)



# AG 400 relay

## Technical specifications

### Dynamic relay selection curve No 6

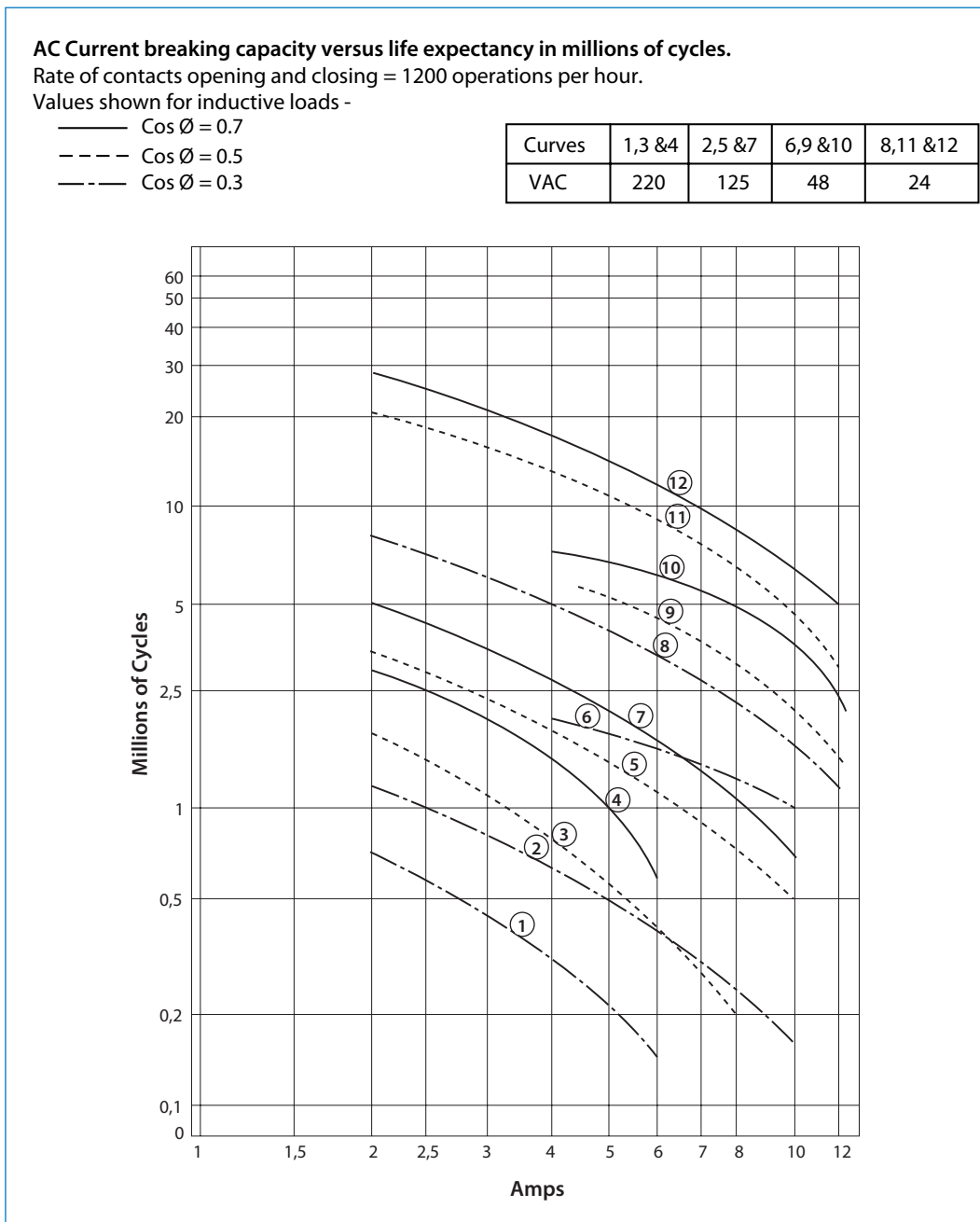

(for specific power contacts on customer circuitry only, not interchangeable into another socket with different customer circuitry configuration)



# AG 400 relay

## Mounting possibilities / sockets

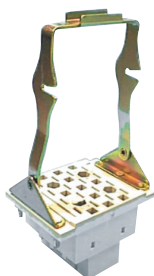

EA 102 A



EA 103 AF



EA 104 A

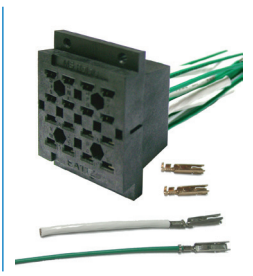

EA 112 AF

### Panel/flush mounting

EA 102 A	Locking bracket (905843), rear connection, double Faston 5 mm
EA 102 AF	Wire locking spring (926853), rear connection, single Faston 5 mm
EA 104 A	Locking bracket (905843), rear connection, single Faston 5 x 0.8 mm
EA 104 AF	Wire locking spring (926853), rear connection, single Faston 5 x 0.8mm
EA 112 AF	Wire locking spring (926853), rear connection, crimp contact

### Surface/wall mounting

EA 103 AF*	Wire locking spring (926853), front connection, M3 screw 6.5 mm ring terminals (2,5 mm <sup>2</sup> )
EA 105 AF*	Wire locking spring (926853), front connection, single Faston 5 mm

\* Mounting possibility on 35 mm rail EN 50022 by adding suffix D to the part number (see socket datasheet)







Note: Keying of relay to socket can be specified by adding the keying letters in the part number. See all details in the related socket datasheet.

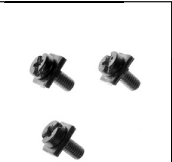
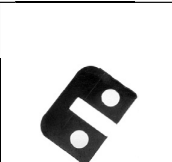

# AG 400 relay

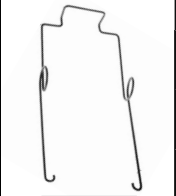
## Spare parts

### Spare parts - order part numbers

<p>(1)</p>  <p>LOCKING BRACKET</p> <p>905843</p>	<p>(1)</p>  <p>SCREW FOR BRACKET</p> <p>C927210</p>	<p>(1)</p>  <p>METAL STRAP (2)</p> <p>P928060</p>	<p>(1)</p>  <p>METAL STRAP (4)</p> <p>P928061</p>
<p>(1)</p>  <p>WIRE LOCKING SPRING</p> <p>926853</p>	<p>(1)</p>  <p>ROUND PLASTIC PLUGS</p> <p>414928005</p>	<p>(2)</p>  <p>HEX. PLASTIC KEYS</p> <p>414905678</p>	<p>(3)</p>  <p>LOCK PINS ASSY 2 SCREWS</p> <p>906364 212903020</p>

(1) Parts only for socket  
 (2) Parts for relay and socket  
 (3) Parts only for relay



# AG 400 relay

## Instructions

### Installation

Install socket and connect wiring correctly according identification to terminals. Plug relay into socket. Reverse installation into socket not possible due to mechanical blocking by snap-lock.

Don't reverse polarity of coil connection. Relays can be mounted (tightly) next to each other and in any attitude.

**Warning!** Never use silicon spray near by relays

### Operation

Before operating always apply voltage to coil to check correct operation.

Long term storage may corrode the silver on the relay pins. Just by plugging the relay into the socket, the female bifurcated receivers will automatically clean the corrosion on the pins and guarantee a good connection.

Do not use the relay in places with flammable gas as the arc generated from switching could ignite gasses.

### Maintenance

Correct operation of relay can easily be checked as transparent cover gives good visibility on the moving contacts. When the relay doesn't seem to operate correct, please check presence of coil voltage. Use a multimeter. If LED is used, coil presence should be indicated. If coil voltage is present, but the relay doesn't work, a short circuit of suppression diode is possible (The coil connection was reversed). If relay doesn't work after inspection, please replace relay unit by a similar model. Send defective relay back to manufacturer. Normal wear and tear excluded.



# AG 400 relay

## Ordering scheme

Configuration:



1. Relay model      2. Nominal voltage      3. Keying      4. Coil OVP      5. Weld no transfer      6. LED ind.      7. Cover type

This example represents a **AG 400 24 AG S C V F**.

**Description:** AG 400 series relay, Unom: 24 VDC, Keying AG, Transil coil protection, Weld no transfer, LED indicator, relay cover for wire locking spring

### 1. Relay model

**AG 400**

### 2 & 3. Nominal voltage and keying

<b>AG</b>	24 VDC
<b>FL</b>	36 VDC
<b>DG</b>	48 VDC
<b>BG</b>	72 VDC
<b>US</b>	96 VDC
<b>SV</b>	110 VDC
<b>EG</b>	125 VDC
<b>SZ</b>	115 VAC
<b>CG</b>	220 VAC

### 4. Coil overvoltage protection

–	No coil protection
<b>P</b>	Avalance diode coil protection
<b>S</b>	Transil coil protection (only with 400 type)

Note: no coil protection for AC coil version

### 5. Weld no transfer option

–	Regular double break contacts
<b>C</b>	Weld no transfer

### 6. LED indicator

–	No LED
<b>V</b>	LED voltage indicator

### 7. Relay cover type

–	Relay cover with lock pins
<b>F</b>	Relay cover for wire locking spring



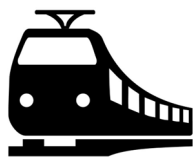

**Mors Smitt France SAS**

Tour Rosny 2, Avenue du Général de Gaulle,  
F - 93118 Rosny-sous-Bois Cedex, FRANCE  
T +33 (0)1 4812 1440, F +33 (0)1 4855 9001  
E [sales.msf@wabtec.com](mailto:sales.msf@wabtec.com)

**Mors Smitt Asia Ltd.**

29/F, Fun Towers, 35 Hung To Road  
Kwun Tong, Kowloon, HONG KONG SAR  
T +852 2343 5555, F +852 2343 6555  
E [sales.msa@wabtec.com](mailto:sales.msa@wabtec.com)

**Mors Smitt B.V.**

Vrieslantlaan 6, 3526 AA Utrecht,  
NETHERLANDS  
T +31 (0)30 288 1311, F +31 (0)30 289 8816  
E [sales.msbv@wabtec.com](mailto:sales.msbv@wabtec.com)

**Mors Smitt Technologies Inc.**

1010 Johnson Drive,  
Buffalo Grove, IL 60089-6918, USA  
T +1 847 777 6497, F +1 847 520 2222  
E [salesmst@wabtec.com](mailto:salesmst@wabtec.com)

**Mors Smitt UK Ltd.**

Graycar Business Park, Barton under Needwood,  
Burton on Trent, Staffordshire, DE13 8EN, UK  
T +44 (0)1283 722650 F +44 (0)1283 722651  
E [sales.msuk@wabtec.com](mailto:sales.msuk@wabtec.com)

**RMS Mors Smitt**

6 Anzed Court, Mulgrave,  
VIC 3170, AUSTRALIA  
T +61 (0)3 8544 1200 F +61 (0)3 8544 1201  
E [sales.rms@wabtec.com](mailto:sales.rms@wabtec.com)