

Features

- Low burden
- Monitors CB in both open & closed condition
- Contacts picked up for healthy supply condition contacts
- Slug time delay
- Hand reset flag indicator
- 2 C/O contacts standard
- Draw out case
- Equivalent function to MVAX31
- 1TM12 specification

Application

The operating element for the 6R MATRIX supervision relay functional elements are designated 6RX & are based on our 6R Series relays.

The operating element of the 6RX31 comprises three 6R heavy duty attracted armature relays as shown below.

Supervision is active with the circuit breaker in the open or closed position via the "a & b" CB auxiliary contacts.

Under healthy conditions, with the CB in the closed position, relay 1 & 2 are energized & if the trip coil becomes open circuited or the supply fails, relay 2 will drop out causing alarm relay 1 to drop out & initiate the local visual indicator & output contacts. Similarly, when the CB is in the open position, relays 1, 2 & 3 are energized enabling the relay to detect failure of the trip circuit coil or supply in the same manner as if closed. Once set the alarm relay flag must be hand reset. If the protection trip contact operates alarm relay 1 will drop out after 300ms (approx.) unless the CB auxiliary contact opens within this time causing relay 3 to pick up. The 300ms delay prevents false alarms due to normal delays in the tripping operation."

Relay 1 element is fitted with a slug to provide a delay of 100ms (approx.) on de-energization to prevent false alarms due to voltage dips in the supply rail. If the protection trip contact should fail to reset, due to a failure of the circuit breaker tripping mechanism for example, the relay drops out initiating the local visual alarm indicator & output contacts.

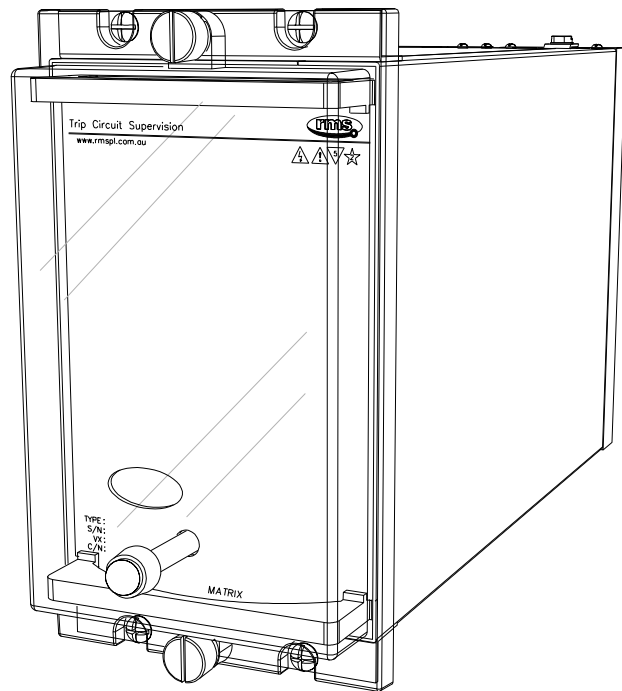

4M28 draw out case

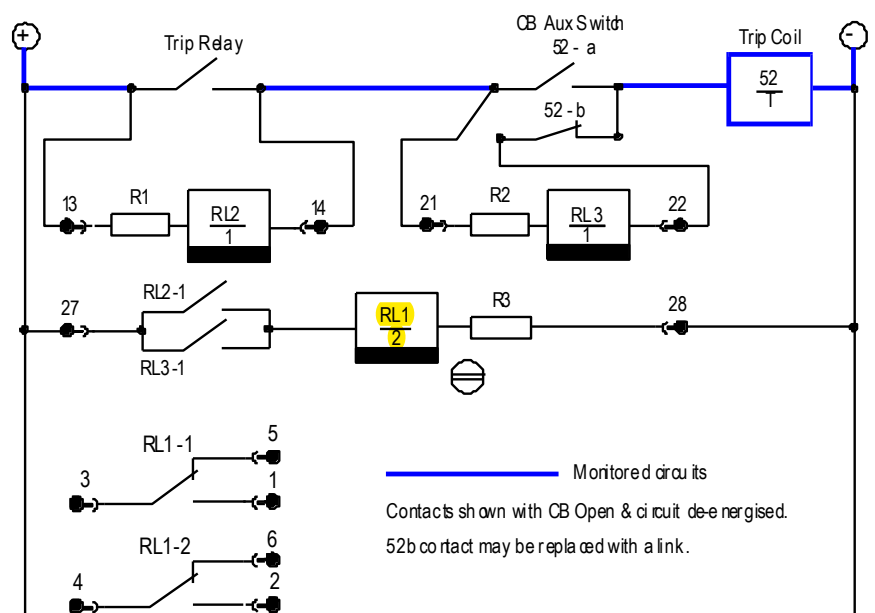

Ordering Codes

CIRCUIT RESISTANCE & BURDEN

The 1TM12 circuit design is optimized to minimize the supervision current in the CB trip coil to avoid the possibility of nuisance tripping. The total series resistance provided by R1 & RL2 is tabulated below. Resistance of the CB coil must be much less than this figure to ensure adequate supervision current flows through the 1TM12 element under normal conditions.

Nominal supply	~Resistance (ohms)	Current (mA)	Burden * (Watts)
32V DC	1,090	30	<1.0
48V DC	1,600	20	<1.5
110V DC	8,100	14	<1.5
125V DC	8,100	15	<2.0
220V DC	25,000	9	<2.0
240V DC	25,000	10	<2.4
250V DC	25,000	10	<2.5

TRIP SUPPLY BURDEN

* Actual operating burden is dependent on the CB coil resistance.

ALARM CIRCUIT BURDEN

Allow a nominal 1 Watt for the alarm relay RL1 which is normally energised under healthy trip circuit conditions.

FLAG OPERATION

Each relay element is supplied with a flag (target) indicator. The indicator consists of a high visibility solid dayglow orange mechanical flag.

Operation: Drops on coil de-energization.
Reset: Hand reset.

OPERATING VOLTAGE RANGE

Guaranteed operation between 80% & 120% of nominal rated operating voltage.

DROP OUT VOLTAGE

Drop out >15% of nominal rated operate voltage.

DROP OUT DELAY

Not less than 100ms when supply is switched from 100% of nominal rated operating voltage to off. Not less than 300ms during trip circuit interruptions.

NOMINAL OPERATING VOLTAGES

24, 32, 48, 110, 125, 220, 240 & 250V DC available.

CONTACTS

2 C/O standard
Up to 4 M or B contacts - user to specify combination of make & break contacts

Generate the required ordering code as follows:
e.g. 6RX31-D

6RX31 -

1

1 NOMINAL OPERATE VOLTAGE

- | | |
|-----------|-----------|
| A 24V DC | E 125V D |
| B 32V DC | G 220V DC |
| C 48V DC | H 240V DC |
| D 110V DC | F 250V DC |

6R RELAY CONTACT RATINGS

Make & Carry Continuously

3,000 VA AC resistive with maximums of 660V & 12A
3,000 W DC resistive with maximums of 660V & 12A

Make & Carry for 3 Seconds

7,500 VA AC resistive with maximums of 660V & 30A
7,500 W DC resistive with maximums of 660V & 30A

AC Break Capacity

3,000 VA AC resistive with maximums of 660V & 12A

DC Break Capacity (Amps)

Voltage	24V	48V	125V	250V
Resistive rating	12	2	0.5	0.25
L/R=40ms Maximum break	12	1	0.25	0.15

INSULATION WITHSTAND in accordance with IEC 255-5:

2KV RMS & 1.2/50 5KV impulse between:

- ◆ all terminals & frame
- ◆ each contact group
- ◆ all contacts & coil

CASE SIZE

4M28-S draw out case

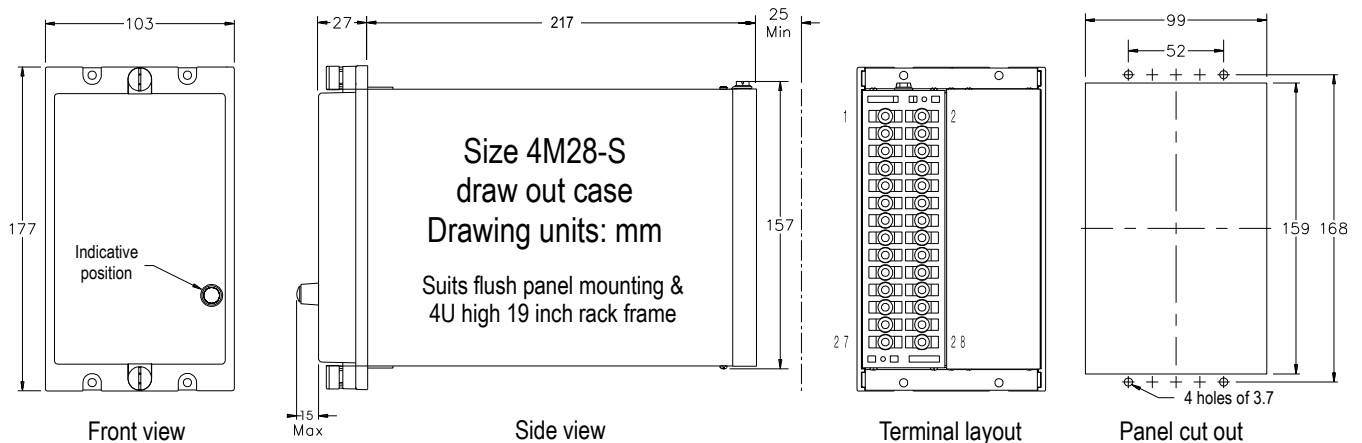



www.rmspl.com.au



Relay Monitoring Systems Pty Ltd design, manufacture and market a wide range of electrical protection and control products for application on high voltage power systems. The company's depth of manufacturing and engineering expertise is backed up by many years of experience since the formation of its predecessor, Relays Pty Ltd (RPL), in 1955. This experience combined with a broad base of field proven product types enables RMS to service specific customer needs by producing relays on demand and with typically short lead times.

Relay Monitoring Systems Pty Ltd

6 Anzed Court
Mulgrave, Victoria 3170
AUSTRALIA
Ph: +61 3 8544 1200
Fax +61 3 8544 1201
Sales: rms@rmspl.com.au
www.rmspl.com.au
www.relays.com.au

ISO9001 Quality Accreditation

RMS holds NCSI (NCS International Pty Limited) registration number 6869 for the certification of a quality system to AS/NZS ISO9001:2008.

Due to RMS continuous product improvement policy the information contained in this document is subject to change without prior notice.

© 2013 Relay Monitoring Systems Pty Ltd

ABN 76 052 484 483