

# Arc Flash Protection 1S27

High speed arc fault protection for metal clad air Insulated switchgear utilizing optical sensors.

- Less than 7ms arc detection and tripping time
- Four (4) point sensor inputs
- Optional linear sensor input
- Surface or rail mount
- Flush panel or rack mount
- Made in Australia





## Features

- > Four-point sensor inputs
- > Optional linear sensor input
- > Four high speed tripping outputs
- > One or two protection zones
- > Front panel reset
- > Continuous arc sensor supervision
- > Integrated self-supervision with fail alarm contact
- > Surface or rail mount
- > Flush panel or rack mount
- > Three (3) auxiliary supplies ranges available covering 19-240V ac and 19-250 Volts dc
- > Panel, rack or rail mount options
- > Compact size 2, 2U high case
- > Plug-in terminal block
- > M4 screw terminals

## Application

Utilised in either new installations or as a simple retrofit in existing installations, the 1S27 provides high speed detection and signalling of arc flash hazards for application in air insulated metalclad switchgear.

Arc Fault protection schemes may be implemented on an Arc only basis, or alternatively a Current Check may be employed where additional security is warranted.

A current checked scheme may be implemented by making use of available protection relay logic and a fast-acting instantaneous overcurrent element.

Some typical application examples are shown on the Application page together with an Example Schematic.

For further Application information refer to the 1S27 User Guide.

The 1S27 is packaged in the Delta size 2, 2U high case that may be flush panel, rack or rail mounted.

A plug in terminal block is provided to allow panel pre-wiring.

## Arc Flash Protection

Arc fault protection is a relatively new technique employed for the clearance of arcing faults on low voltage panels, MCC's, BUS bars and within metal clad switchgear and associated cable boxes.

Conventional current based protection techniques are at times challenged by the nature of arcing faults, and can result in slow protection clearance times. Slow protection clearance times increase the risk to nearby personnel and increase the degree of damage to plant and equipment.

By employing an optical detection technique, Arc Fault Protection results in fast clearance of arcing faults.

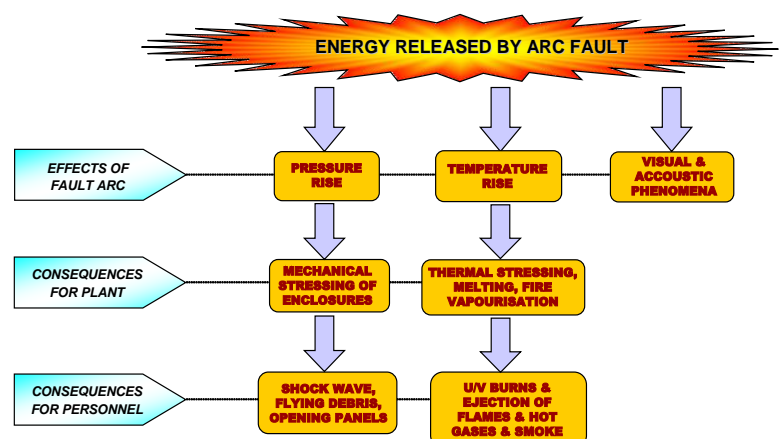

## Front Panel Layout

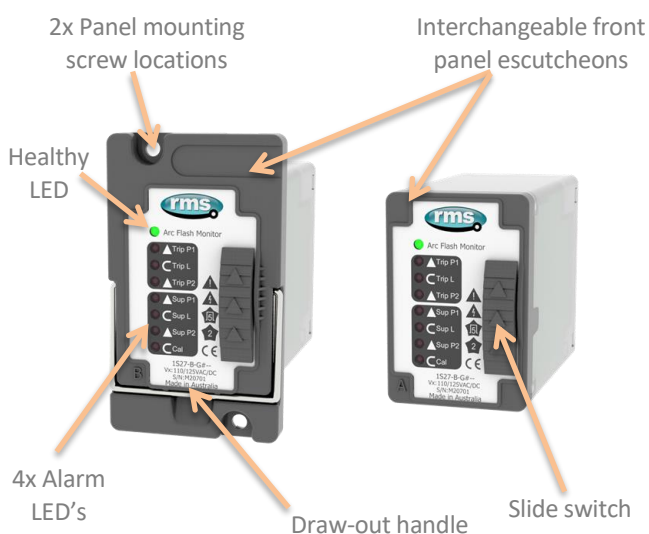

Figure: 1: 1S27 front panel  
 Left – Panel mount      Right – rail mount

## Front Panel Configuration

Delta relays can be easily converted from a rail mount to a flush mount configuration. This is achieved by un-clipping the front rail mount escutcheon, securing a metal panel mount plate with four (4) screws and clipping on a panel mount escutcheon. This process may be reversed to convert from a panel mount to a rail mount version.

Delta relays may be ordered with the desired configuration or converted by the user using one of the conversion kits listed in the ordering section.



## Supervision Healthy LED's

A front panel green LED is provided to indicate when the 1S27 is powered up and all connected arc sensors are operating correctly. Should any of the sensors become disconnected the associated red supervision LED will be illuminated. Healthy sensors will continue to operate normally.

## Supervision Alarm Contact

The supervision alarm contact is picked-up when all monitored circuits are in the HEALTHY condition. FAILURE of a supervision circuit will cause the alarm contact to drop out to signal an alarm condition.

## Arc Trip Indication

A red LED is provided to indicate an arc trip event zone and the type of sensor to assist with fault location.

- ▲ Zone 1 Trip - Point sensors
- ▭ Zone 1 Trip - Linear sensor
- ▲ Zone 2 Trip - Point sensors

This trip indication will remain latched until the front reset slide or the remote reset input is activated. The associated output trip contact(s) will also operate and self-reset in 1s.

## Reset Slide Switch

The reset slide switch is used for several functions:

- Reset trip LED's (Fast operate and release)
- Display relay settings (Hold for >2s)
- To gain access to the configuration switch and rotate to change relay settings

## Calibration Indication

The Cal LED will commence flashing if the linear sensor fails the automatic calibrate routine.

## Display Relay Settings

To review the relay settings, lift and hold the reset slide switch until a combination of LED's commence flashing.

1S27-A LED's for trip and sensor configuration will be displayed in accordance with Table 1.

1S27-B As per the 1S27-A alternating with LED's for the linear sensor transmission length in accordance with Table 3.

## Terminal Block

- TBD-R1 /R2      Rear connect terminal block  
 Suitable for flush mount relay version
- TBD-F            Front connect terminal block  
 Suitable for rail mount relay version

## Arc Sensors

The 1S27 is designed to monitor remote optical sensors that respond to the flash of light emitted during the incidence of an arcing fault. Onset of the light flash & detection by the sensors occurs in a few ms.

## 1S30 Point Sensor

The 1S30 is an electrically wired point sensor suitable for application in discrete compartments in metal clad switchgear and cable ducts. When an arc is detected, the resistance presented by the 1S30 drops to a level where the current flow increases to approximately 20mA. This increased current flow is instantaneously detected by the 1S27 & its trip output contacts closed. Refer to the 1S30 Technical Bulletin for further details.



Figure 2: 1S30 Point Sensors

## 1S30 Shielded Cables

Shielded cables are recommended when the length of the 1S30 cable connections exceed 6m.

## 1S40 Linear Sensor

The 1S40 linear sensor may be applied to protect large volumes where multiple point sensors would otherwise be required. A separate 1S40 linear sensor is required for each segregated protection zone. Refer to the 1S40 Technical Bulletin for further details.

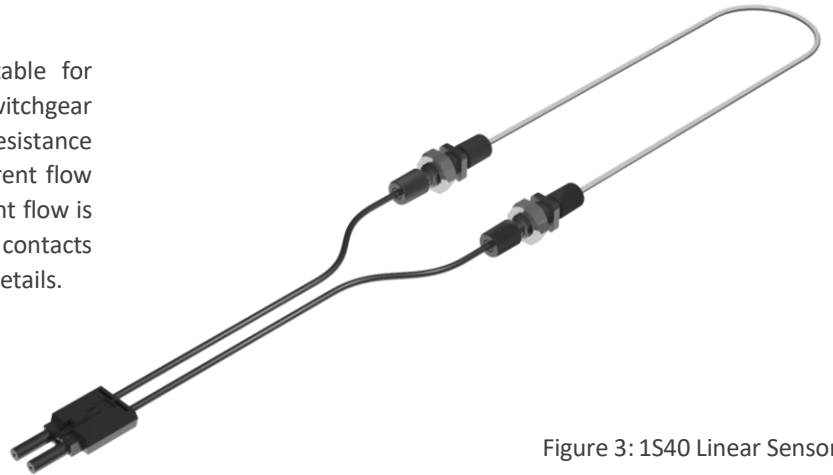

Figure 3: 1S40 Linear Sensor

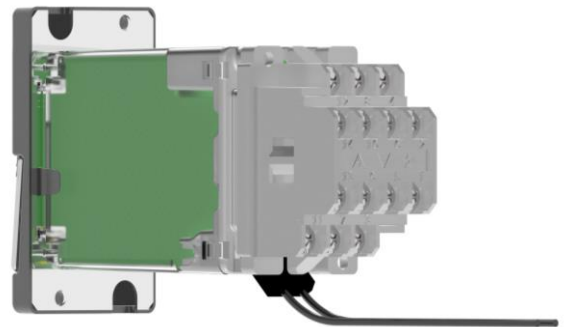

Figure 4: 1S40 Linear Sensor Connection

## Arc Fault Tripping Using Current Check

Fast operation of a tripping scheme usually results in reduced system security. The arc detection method can however, combine the 1S27 optical detection technique with a traditional overcurrent method to maximize system security particularly for BUS bar protection schemes. Both conditions must coexist for the trip condition to be met as depicted in Figure 5.

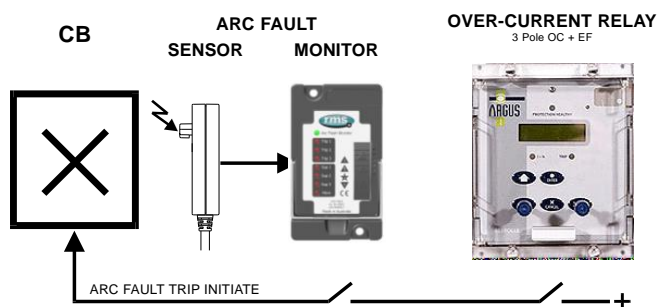

Figure 5:

Key components required to implement an Arc Fault Protection scheme with an overcurrent check stage to enhance system security.

The application examples in Figures 6 to 10 utilize this concept for enhanced system security in that both the 1S27 AND the OC 50 starter contact must be picked up for a CB trip signal to be initiated. As the arc fault trip contact picks up considerably faster than the overcurrent relay starter element, the CB trip time will be dictated by the overcurrent relay performance.

## Low Current Arcing Faults

Arcing faults can occur at low current levels & it is possible for the over-current starter element to be set above this level. To avoid this problem & obtain very fast clearance (<7ms), of an arc fault, the 1S27 arc fault trip contact may be wired directly to the breaker operate coil. It should be noted that this method may lead to reduced system security.

## Arc Detection Reset Time

(Effect of multiple arc trips)

A delay of 2s is required to reset the 1S27 after an initial arc sensor trip. Subsequent arc detection will cause the trip output contacts to re-operate.

## Arc Sensor Continuously Picked Up

High ambient light levels may cause a 1S30 or 1S40 to be continuously picked up. This condition could occur for example if the CB cable box cover was left open in very high ambient light level conditions.

To avoid possible mal operation due to this condition, the 1S27 is designed to automatically disable the arc fault tripping function if any sensor input is picked up for >10s. The 1S27 alarm contact will be set & the front LED flash alternate orange & red until the ambient light level problem is corrected. The 1S27 will then perform an arc sensor test function & automatically reset.



## Switchgear ARC Flash Protection

Risk of arc fault damage exists at the CB cable termination and in the CB chamber itself. The CB cable termination is particularly at risk to ingress of moisture and rodent damage.

One, two or three arc sensors may be connected to the 1S27 Arc Fault Monitors as depicted in the single line application diagrams at right.

Figures 5 and 6 show the trip signals being used to trip the feeder circuit breaker in the event of an arc fault occurring at any sensor provided the overcurrent relay starter contact is picked up. In these applications the overcurrent check stage is optional as the consequence of a single feeder outage is less than the loss of an entire BUS.

Figure 7 shows an application where a single 1S27 is applied for the protection of the Cable box, CT chamber and CB chamber using three sensors. In this configuration one arc trip output is used to trip the feeder circuit breaker in the event of an arc fault in the cable box / CT chamber. The second trip output is set for independent operation to trip the BUS breaker (BUS overcurrent check not shown), in the event of an arc fault in the CB chamber.

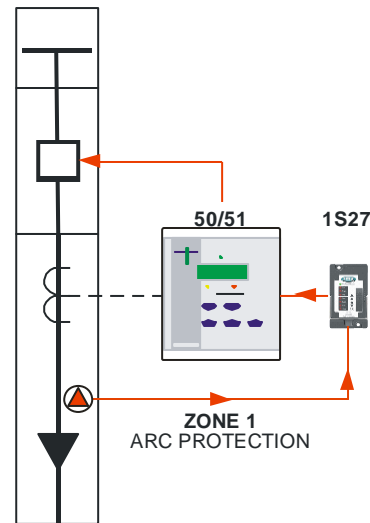

Figure 5:  
One point sensor in zone 1 for Cable box  
1S27-A Selector switch position 1 or 5

## Existing Switchgear Applications

The existing overcurrent relay protecting the feeder will normally provide an independent output contact associated with the start current setting of the relay. That is an output contact that will close when a phase or earth fault current is detected above the threshold which starts the internal relay timers. This starter element should be set for instantaneous operation so that it will pick up in the order of 10-15ms.

An Arc Fault Monitor relay 1S27 is installed on the switchgear panel adjacent to the protection relay. The 1S27 is specifically designed for simple retrofit to existing panels or DIN rail mounted within the instrument chamber.

1S30 optical arc sensors are fitted in the cable termination box and CT chamber as depicted in Figure 6.

The overcurrent relay starter contact may optionally be wired in series with the arc fault detection trip output contact as depicted in Figure 6. The resulting “AND” function trip output is wired to initiate breaker trip in 10-15ms in the event that an arc fault is detected while the overcurrent start element is picked up.

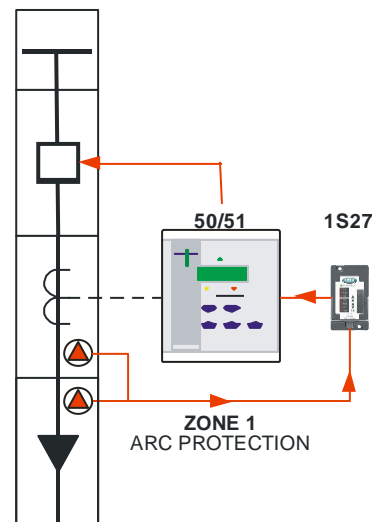

Figure 6:  
Two point sensors in zone 1 for Cable box and CT chamber  
1S27-A Selector switch position 2 or 6

## New Switchgear Applications

For new switchgear installations a modern numeric feeder protection relay is likely to be employed which will have numerous programming and configuration options.

The basic concept is the same as for the existing switchgear application described above except that the additional features and flexibility of modern feeder protection relay allows improved system integration.

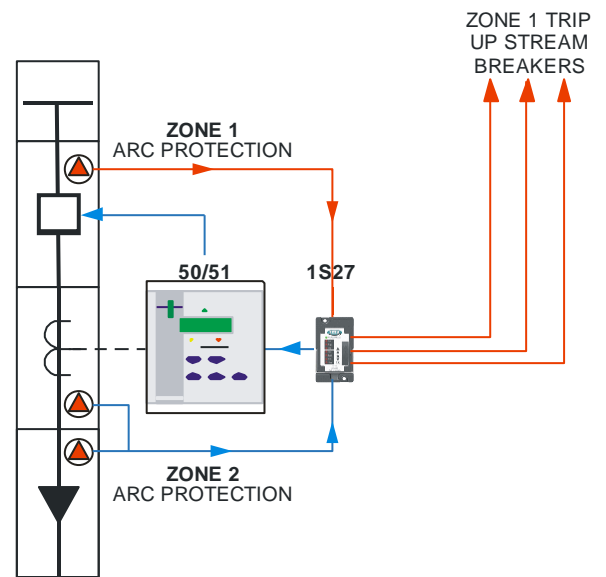

Figure: 7:

- One point sensor in zone 1 for CB chamber
- Two point sensors in zone 2 for Cable box and CT chamber
- 1S27-A Selector switch position 7

## Combined Bus Bar and Switchgear Arc Protection

Figure 8 shows an application where a single 1S27 is applied for the protection of the Cable box and CT chamber plus the CB chamber and BUS chamber using a linear sensor.

In this configuration one arc trip output is used to trip the feeder circuit breaker in the event of an arc fault in the cable box / CT chamber. The second trip output is set for independent operation to trip the BUS breaker (BUS overcurrent check stage not shown), in the event of an arc fault in the CB chamber or BUS chamber.

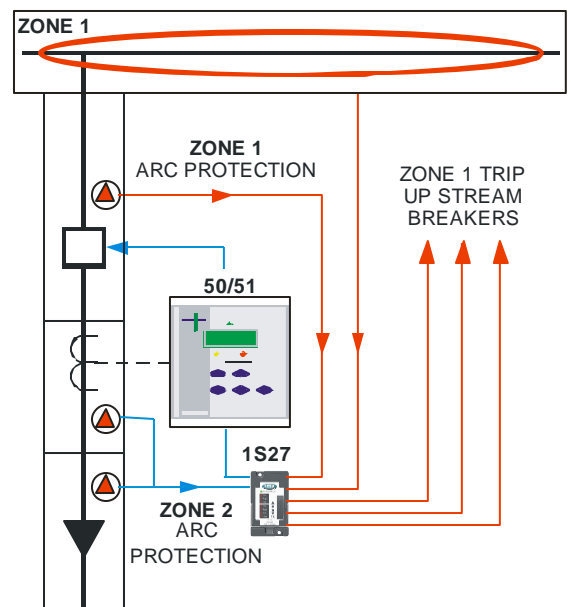

Figure: 8:

- Linear sensor in zone 1 for BUS chamber
- One point sensor in zone 1 for CB chamber
- Two-point sensors in zone 2 for Cable box and CT chamber
- 1S27-B Selector switch position 7

## Bus Bar Arc Protection

Figure 9 depicts how the 1S27 may be applied for the protection of a bus bars system with multiple incoming and outgoing and feeders. In this example there are three incoming circuits, a bus duct divided into three sections and separated by two bus ties. Multiple feeders are connected to each bus section.

1S40 linear arc sensors are employed to monitor the three bus bar ducts. 1S30 point sensors are employed to monitor key switchgear compartments.

## Hardware Code and Configuration Settings

For the scheme depicted in Figure 9 to function correctly, the 1S27 arc fault modules need to be specified and configured as follows:

Symbol	1S27 Hardware Code	Configuration
<b>A1</b>	A	1
<b>A6</b>	A	7
<b>B1</b>	B	1

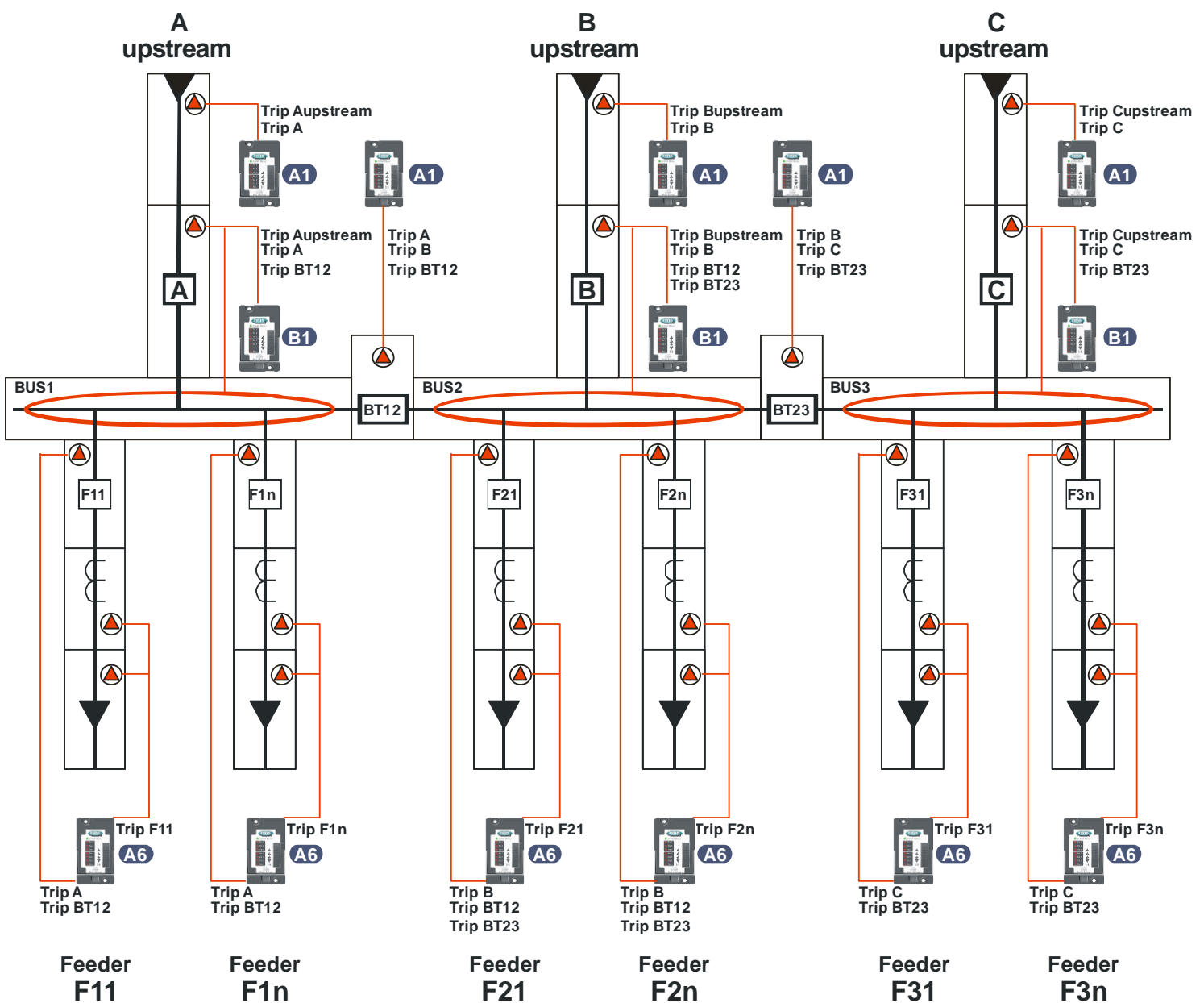

Figure 9: Bus bar arc protection single line schematic



## Sensor Versions

The 1S27 is available with two (2) sensor versions:

- > 1S27-A Point sensor inputs (Up to 4x 1S30 sensors)
- > 1S27-B As per the 1S27-A + Optic fibre linear sensor input (1x 1S40 sensor)

## Operating Modes

The 1S27 has three modes:

### 1. Normal Operating Mode

The 1S27 starts in this mode when powered up.

### 2. Setting Display Mode

With the slide switch held up for 2s, the 1S27 enters the setting display mode.

1S27-A LED's for trip and sensor configuration will be displayed in accordance with Table 1.

1S27-B As per the 1S27-A alternating with LED's for the linear sensor transmission length in accordance with Table 3.

### 3. Configuration Mode

The configuration mode is entered when a setting change is made by adjustment of the rotary selector switch. When this occurs the green Arc Flash Monitor LED will commence flashing.

Also refer to Configuration Selection Indication.

## Function Configuration

The 1S27 may be configured to suit a wide range of arc flash monitoring applications.

The configuration setting is selected via a rotary switch accessible when the front panel slide switch is operated as shown in Figure 10. Positions 0-9 are employed for trip and sensor function configuration.

The single digit configuration code required to set the 1S27 is determined from the selection matrix shown in Tables 1.

Note that the setting must be carried out with the 1S27 powered up so that the selected configuration is stored at the completion of the setting process when the slide switch is released.

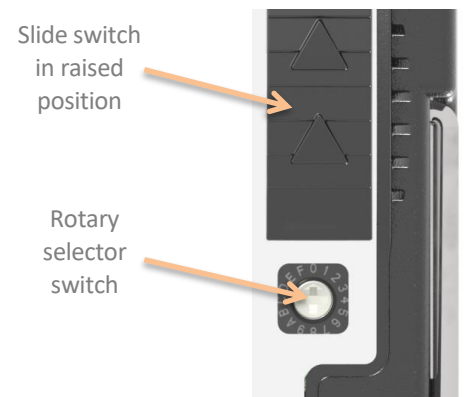
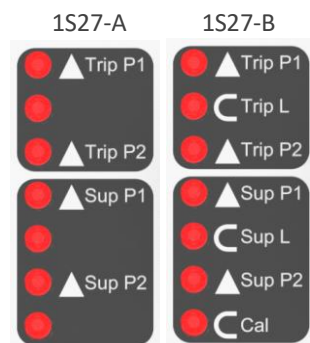

Figure 10: Front panel configuration setting switch for 1S27-B

## Configuration Selection Indication

The rotary switch may be adjusted using a small blade screw driver to the required position 0 to 9 with the front panel LED's responding by changing to a unique position to allow easy setting verification as per Table 1. Release the slide switch for the new setting to be stored in memory.



Configuration Switch Setting									
0	1	2	3	4	5	6	7	8	9
Front Panel Indication During Function Configuration									
Flashing <span style="color: green;">●</span> Arc Flash Monitor									
●					●	●	●	●	●
	●				●				
		●				●			
			●				●		
				●				●	
					●				●
									●

Table 1

## Common Tripping Configuration

Common Tripping – All connected sensors are mapped to trip contacts 1, 2, 3 and 4.

### 1S27-A

Common Tripping Scheme		Sensor Type	Configuration Switch Setting				
			0	1	2	3	4
Number of Sensors Connected	Input 1	1S30	0	1	1	1	2
	Input 2	1S30	0	0	1	2	2

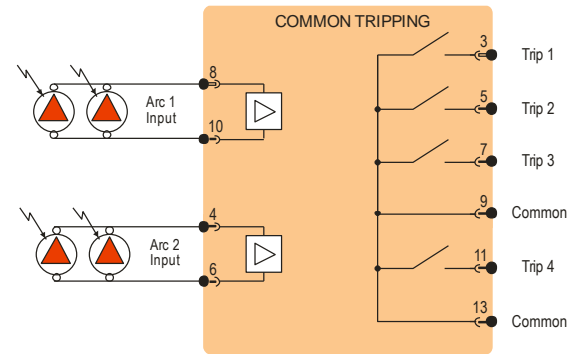

### 1S27-B

Common Tripping Scheme		Sensor Type	Configuration Switch Setting				
			0	1	2	3	4
Number of Sensors Connected	Linear	1S40	1	1	1	1	1
	Input 1	1S30	0	1	1	1	2
	Input 2	1S30	0	0	1	2	2

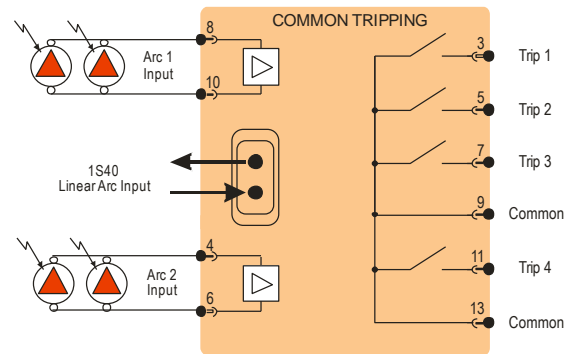

Configuration Switch Setting						
0	1	2	3	4		
Front Panel Indication During Function Configuration						
Flashing  Arc Flash Monitor						
•						
	•					
		•				
			•			
				•		
					•	

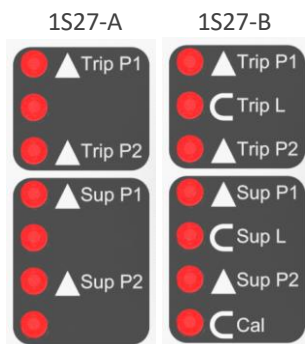

Table 1a

## Zone Tripping Configuration

Zone Tripping – All sensors connected to INPUT 1 and LINEAR are mapped to trip contacts 1, 2 and 3 for ZONE 1.

Zone Tripping – All sensors connected to INPUT 2 are mapped to trip contact 4 for ZONE 2.

### 1S27-A

Zone Tripping Scheme		Sensor Type	Configuration Switch Setting				
			5	6	7	8	9
Number of Sensors Connected	Input 1	1S30	1	1	1	2	2
	Input 2	1S30	0	1	2	1	2

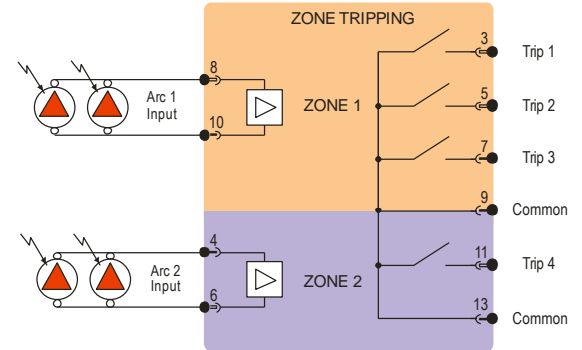

### 1S27-B

Zone Tripping Scheme		Sensor Type	Configuration Switch Setting				
			5	6	7	8	9
Number of Sensors Connected	Linear	1S40	1	1	1	1	1
	Input 1	1S30	1	1	1	2	2
	Input 2	1S30	0	1	2	1	2

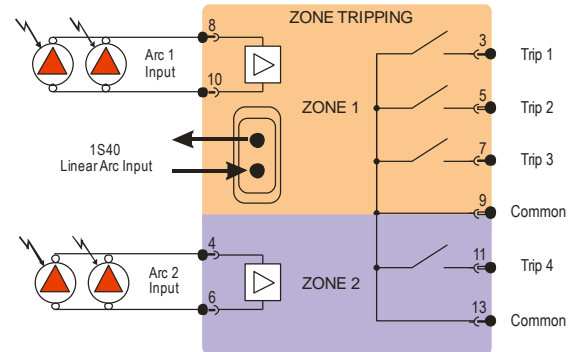

		Configuration Switch Setting				
		5	6	7	8	9
1S27-A	Trip P1	●	▲			
	Trip L	●	○			
1S27-B	Trip P1	●	▲			
	Trip L	●	○			
1S27-A	Sup P1	●	▲			
	Sup L	●	○			
1S27-B	Sup P1	●	▲			
	Sup L	●	○			
1S27-A	Sup P2	●	▲			
	Sup P2	●	▲			
1S27-B	Sup P2	●	▲			
	Sup P2	●	▲			
1S27-A	Cal	●	○			
	Cal	●	○			

		Front Panel Indication During Function Configuration				
		5	6	7	8	9
1S27-A	Flashing	●	●	●	●	●
	Arc Flash Monitor	●	●	●	●	●
1S27-B	Flashing		●			
	Arc Flash Monitor		●			
1S27-A	Flashing			●		
	Arc Flash Monitor			●		
1S27-B	Flashing				●	
	Arc Flash Monitor				●	
1S27-A	Flashing					●
	Arc Flash Monitor					●

Table 1b

## 1S40 Linear Sensor

This section relates to the 1S27-B version and the configuration required to operate with a 1S40 Linear Arc Sensor.

When connecting a 1S40 linear sensor, the 1S27 must be configured with the correct setting corresponding to the length of the optic fibre transmission section shown in Figure 11 and listed in Table 2. The transmission section fibre must be cut to one of the set lengths as specified in Table 2 within a tolerance of 10%.

*This step should only be undertaken after the 1S27 Function Setting has been set as described under Function Configuration.*

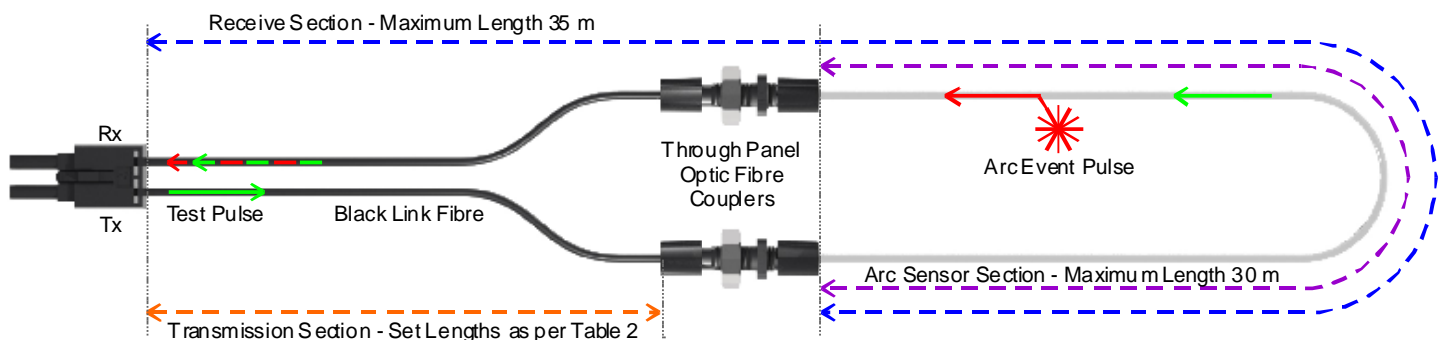

Figure 11:

1S40 Component Function and Installation Limitations

Transmission Section Length	Setting
<1 metre	A
1 metres	B
5 metres	C
10 metres	D
20 metres	E
30 metres	F

Table 2

## Arc Sensor Auto Calibration

When the arc monitor unit is powered up or a setting change confirmed, a calibration routine is automatically initiated to adjust the detection gain and threshold for the deployed sensor. The output intensity of the supervision pulse used for calibration is set based on the Transmission Section Length setting. If a suitable threshold cannot be set during calibration the Calibration fail LED is illuminated to indicate that the 1S40 connections and configuration setting should be checked.

## 1S27-B Linear Sensor Configuration

The linear sensor configuration is set via a rotary switch accessible when the front panel slide switch is operated as shown in Figure 10.

A 16-position rotary switch is employed for 1S27-B version relays. Positions A-F are used to select the Transmission Section Length setting in accordance with Table 2.

Note that the setting must be carried out with the 1S27 powered up so that the selected setting is stored at the completion of the setting process when the slide switch is released.

1S27-B	Configuration Switch Setting					
	A	B	C	D	E	F
	Front Panel Indication for 1S40 Configuration					
	Flashing  Arc Flash Monitor					
• ▲ Trip P1	•					
• ◐ Trip L		•				
• ▲ Trip P2			•			
• ▲ Sup P1				•		
• ◐ Sup L					•	
• ▲ Sup P2						•
• ◐ Cal	•	•	•	•	•	•

Table 3

## Auxiliary Supply

Low Range Version	Order Code F
Nominal Voltage Supply (Shown on relay front panel)	24 / 32 / 48 ac/dc
Standards Compliant Range	19-85V dc 19-65V ac
Absolute Range	18-100V dc 15-75V ac
Mid-Range Version	Order Code G
Nominal dc Voltage Supplies (Shown on relay front panel)	110 / 125 ac/dc
Standards Compliant Range	45-165V dc 40-150V ac
Absolute Range	36-200V dc 40-175V ac
High Range Version	Order Code H
Nominal dc Voltage Supplies (Shown on relay front panel)	220 / 240 / 250 ac/dc
Standards Compliant Range	125-250V dc 94-240V ac
Absolute Range	100-300V dc 75-275V ac
Allowable breaks/dips in supply (Collapse to zero)	As per IEC60255-26 *7.2.11
Burden - Quiescent	8W at 110V dc
Burden - Maximum	15W at 110V dc

## Trip Outputs

Operating Voltage	Voltage free
Operating Mode	Self-reset
Trip Contact Operate Time	<7ms (Flash to contact closure)
Reset Time	1s
Making Capacity	
Carry Continuously	5A ac or dc
Make and Carry L/R ≤ 40ms and ≤ 300V	20A ac or dc for 0.5s 30A ac or dc for 0.2s
Breaking Capacity	
	L/R ≤ 40ms and ≤ 300V
AC Resistive	1,250VA
AC Inductive	250VA at p.f. ≤ 0.4
DC Resistive	75W
DC Inductive	30W at L/R ≤ 40ms 50W at L/R ≤ 10ms
Minimum Load	100mA ≥12V

## Supervision Alarm Output Contact

Contact material	Ag (Au Clad)
Operating Voltage	Voltage free
Isolation across open contacts	1 kV rms
Make and carry	0.5 A continuous at 125 V ac
Peak inrush current	2 A
Switching voltage:	
Maximum	220 V dc / 250 V ac
Minimum	10 mV dc
Minimum switching current	10uA

## Arc Fault Point Sensor Inputs

Number	4
Type	1S30 point sensors
Connection	Electrical termination
Zones	1 or 2
Supervision duration	Continuous

## Arc Fault Linear Sensor Inputs (1S27-B version only)

Number	1
Type	1S40 linear sensors
Connection	Rx and Tx optic fibre ports
Zones	1
Supervision duration	<1ms
Supervision interval	2.5 minutes

## ELECTRICAL ENVIRONMENT

### AC and DC Voltage Dips

Standard	IEC 60255-26, #7.2.11
Test Level	Test specification
Dip to 0% of residual voltage Acceptance criterion A	DC: 20 ms AC: 1 cycle 50/60 Hz
Dip to 40% of residual voltage Acceptance criterion C	DC: 200 ms AC: 10/12 cycles 50/60 Hz
Dip to 70% of residual voltage Acceptance criterion C	DC: 500 ms AC: 25/30 cycles 50/60 Hz

### AC and DC Voltage Interruptions

Standard	IEC 60255-26, #7.2.11 Acceptance criterion C
Test Level	Test specification
Drop to 0% of residual voltage	DC: 5 s AC: 250/300 cycles 50/60 Hz

### AC Component in DC (Ripple)

Standard	IEC 60255-26, #7.2.12 Acceptance criterion A
Test Level	Test specification
15% of rated DC value	100/120 Hz, Sinusoidal

### Gradual Shut-down/Start-up (DC Power Supply)

Standard	IEC 60255-26, #7.2.13 Acceptance criterion C
Test Identification	Test specification
Shut-down ramp	60 s
Power off	5 min
Start-up ramp	60 s

### Clearances and Creepage Distances

Standard	IEC 60255-27, #10.6.3
Test Identification	Test specification
Pollution degree	2
Overvoltage category	III
Rated insulation voltage	300 V rms or dc
Clearances and Creepage Compliance	CAD drawings assessment

## Safety-related Electrical Tests

Standard	IEC 60255-27, #10.6.4
Test Identification	Test specification
Between Independent Circuits	5 kV 1.2/50 $\mu$ s 0.5 J 3 pulses of each polarity 2.0 kV ac rms for 1 minute
Any Terminal and Earth	5 kV 1.2/50 $\mu$ s 0.5 J 3 pulses of each polarity 2.0 kV ac rms for 1 minute
Across Normally Open Contacts	1 kV ac rms for 1 min
Protective Bonding Resistance	< 0.1 $\Omega$ at 20 A

## Electrical Environment and Flammability

Standard	IEC 60255-27, #10.6.5
Test Identification	Test specification
Single-fault condition	Assessment
Maximum temperature of accessible parts at ambient temperature +40°C	Metal parts: < 70°C Non-metallic parts: < 80°C
Flammability of insulating materials, components and fire enclosures	Assessment

## Reverse Polarity and Slow Ramp Test

Standard	IEC 60255-27, #10.6.6
Test Identification	Test specification
Maximum voltage dc	V start-up + 20%
Minimum voltage dc	V shutdown - 20%
Ramp down/up gradient	1 V/min



## ATMOSPHERIC ENVIRONMENT

### Temperature

Standard	IEC 60068-2-1, IEC 60068-2-2	
Test Identification	Test specification	Auxiliary power Supply voltage
Operating Range	-10 to +55°C	Min and Max
Storage Range	-25 to +70°C	Non-energized
Test duration	16 h at top and bottom temperatures	

### Damp Heat (Humidity)

Standard	IEC 680068-2-78	
Test Identification	Test specification	
Operating Range	40°C and 93% RH non-condensing	
Test duration	16 h	

### IP Rating

Standard	IEC 60529	
Test Identification	Test specification	
Installed	IP5x	

## MECHANICAL ENVIRONMENT

### Vibration - Sinusoidal

Standard	IEC 60255-21-1 Class 1	
Test Identification	Test specification	Variation
Vibration Response in each of 3 axes	0.035 mm/0.5 gn peak 1 sweep cycle 10-150 Hz	No Mal-Op
Vibration Endurance in each of 3 axes	1.0 gn peak 20 sweep cycles 10-150 Hz	Non-energized

### Shock and Bump

Standard	IEC 60255-21-2 Class 1	
Test Identification	Test specification	Variation
Shock Response in each of 3 axes	5 gn, 11 ms, 3 pulses in each direction	No Mal-Op
Shock Withstand in each of 3 axes	15 gn, 11 ms, 3 pulses in each direction	Non-energized
Bump Test in each of 3 axes	10 gn, 16 ms, 1,000 bumps in each direction	Non-energized

### Seismic

Standard	IEC 60255-21-3 Class 1	
Test Identification	Test specification	Variation
Seismic Response Horizontal, on each axis	3.5 mm/1.0 gn, 1 sweep cycle 1-35Hz	No Mal-Op
Seismic Response Vertical	1.5 mm/0.5 gn, 1 sweep cycle 1-35Hz	No Mal-Op

## ELECTROMAGNETIC COMPATIBILITY (EMC)

### IMMUNITY

#### Electrostatic Discharge (ESD)

Standard	IEC 60255-26, #7.2.3, Acceptance criterion B	
Port	Enclosure	
Test Identification	Test specification	Variation
Air Discharge	8 kV	No Mal-Op

#### Radiated Electromagnetic Field

Standard	IEC 60255-26, #7.2.4, Acceptance criterion A	
Port	Enclosure	
Test Identification	Test specification	Variation
Frequency sweep	10 V rms, 80 to 1000 MHz 1400 to 2700 MHz	No Mal-Op
Spot frequencies	10 V rms, 80, 160, 380, 450, 900, 1850 & 2150 MHz	No Mal-Op

#### Fast Transients (EFT)

Standard	IEC 60255-26, #7.2.5, Acceptance criterion B	
Port	Auxiliary power supply, Input and Output, Functional Earth	
Test level	Test specification	Variation
Zone A	4 kV peak, 5/50 ns, 5 kHz	No Mal-Op

#### Slow Damped Oscillatory Wave (HFD)

Standard	IEC 60255-26, #7.2.6, Acceptance criterion B	
Port	Auxiliary power supply, Input and Output	
Test Identification	Test specification	Variation
Common Mode	1 MHz 2.5 kV peak	No Mal-Op
Differential Mode	1 MHz 1.0 kV peak	No Mal-Op

### Surge

Standard	IEC 60255-26, #7.2.7, Acceptance criterion B	
Port	Auxiliary power supply, Input and Output	
Test Identification	Test specification	Variation
Line-to-earth	4 kV peak	No Mal-Op
Line-to-line	2 kV peak	No Mal-Op

## Conducted Disturbance Induced by RF Fields

Standard	IEC 60255-26, #7.2.8, Acceptance criterion A	
Port	Auxiliary power supply, Input and Output, Functional Earth	
Test Identification	Test specification	Variation
Frequency sweep	10 V rms, 0.15 to 80 MHz	No Mal-Op
Spot frequencies	10 V rms, 27 & 68 MHz	No Mal-Op

## Power Frequency Magnetic Field

Standard	IEC 60255-26, #7.2.10	
Port	Enclosure only	
Test Identification	Test specification	
Continuous $\geq 60$ s	30 A/m - Acceptance criterion A	
Short time 1 s to 3 s	300 A/m - Acceptance criterion B	

## EMISSION

### Emission Enclosure

Standard	IEC 60255-26, #5.1	
Test Identification	Frequency range	Limits, dB ( $\mu$ V/m)
Radiated emission <1 GHz	30 - 230 MHz	40, quasi peak at 10 m 50, quasi peak at 3 m
	230 - 1000 MHz	47, quasi peak at 10 m 57, quasi peak at 3 m
Radiated emission >1 GHz	1 – 3 GHz	56, average 76, peak at 3 m
	3 – 6 GHz	60, average 80, peak at 3 m

### Emission Auxiliary Power Supply Port

Standard	IEC 60255-26, #5.2	
Test Identification	Frequency range	Limits, dB ( $\mu$ V/m)
Conducted emission	0.15 – 0.50 MHz	79, quasi peak 66, average
	0.5 - 30 MHz	73, quasi peak 60, average

## 1S27 Wiring Diagram

(1S40 connection with 1S27-B only)

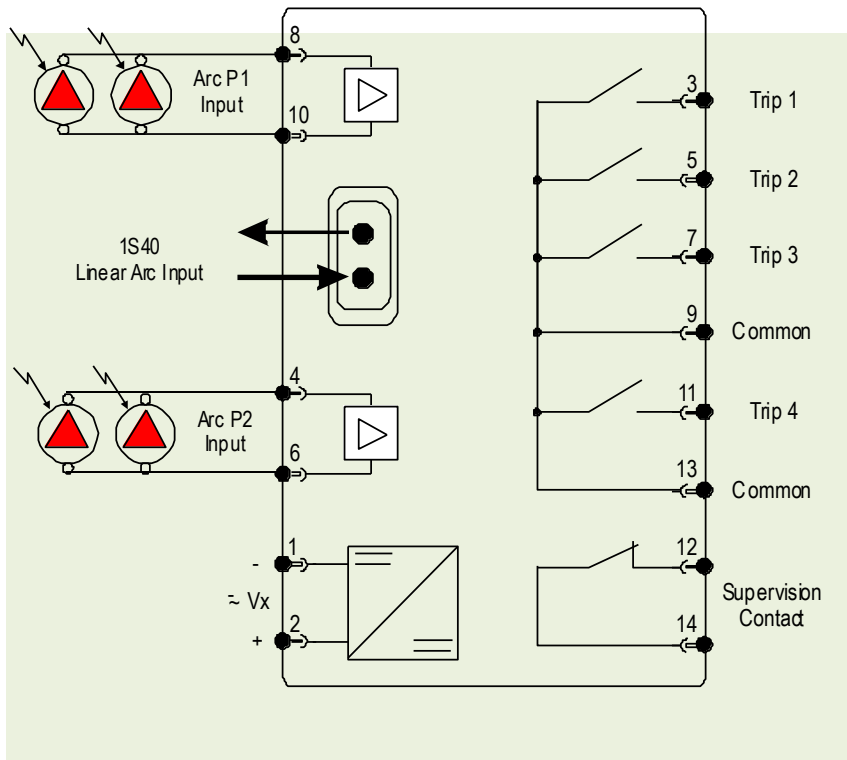

## Wiring Notes

1. Relays are shown in the non-powered condition.
2. Note that the number of connected sensors per input must correspond to the configuration setting to ensure correct sensor supervision function.
3. The 1S27-B version must have a 1S40 linear sensor connected to ensure correct supervision function.
4. Common terminal 9 and 13 must both be connected to ensure the rated current carrying capacity of the trip contacts is maintained.

## 19 Inch Rack Mount Rear Connect (TBD-R Terminal Block)



19-inch rack mount  
2U x 2U



Adapter plate for 2x units  
in a 2U x 4U rack frame



Adapter plate for 4x units  
in a 4U x 4U rack frame

## Surface Mount Rear Connect (TBD-R Terminal Block)

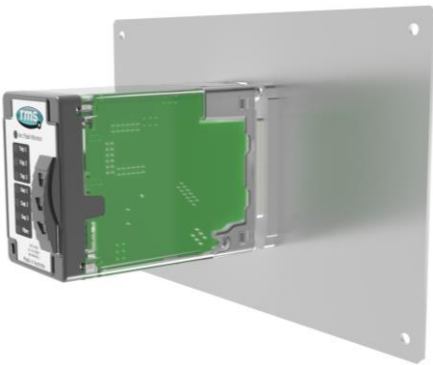

Panel cut-out to mount surface rear  
connect base

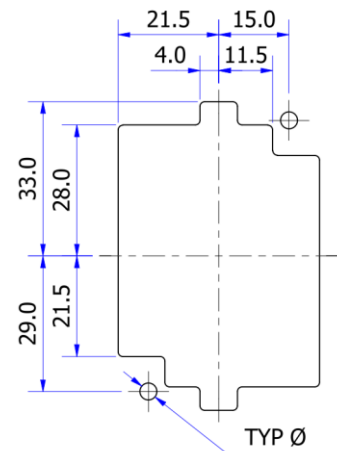
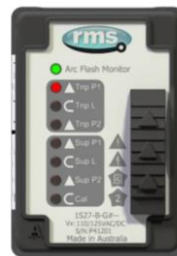
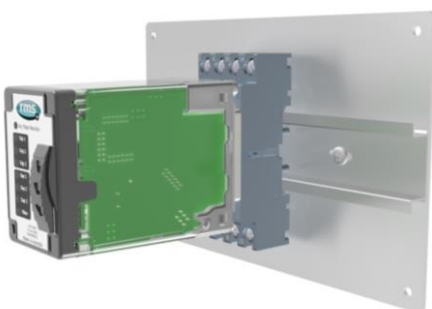
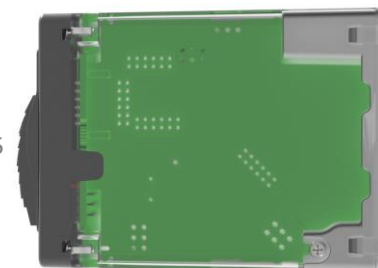

TABLE 1 - HOLE DIA	
PANEL THICKNESS (T)	HOLE DIA (Ø)
1mm < T < 2mm	3.6mm
T > 2mm	3.7mm

## Surface or Rail Mount Front Connect (TBD-F Terminal Block)



65



94



30



87

45

## Flush Panel Mount Rear Connect (TBD-R Terminal Block)

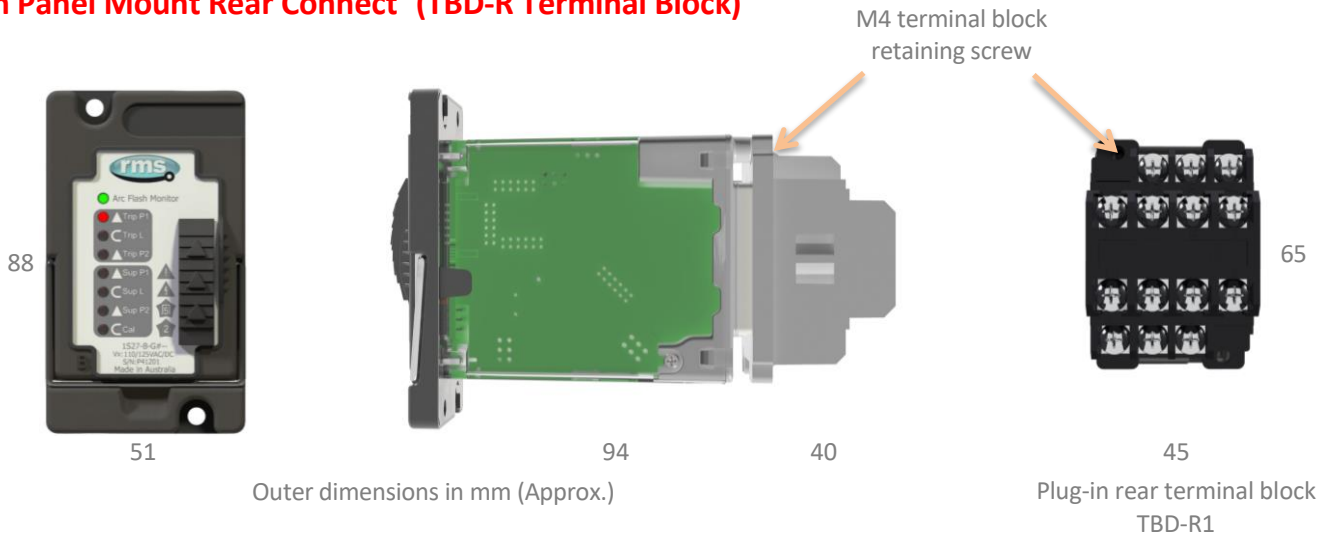

Flush panel mounting  
Rear connect terminal block

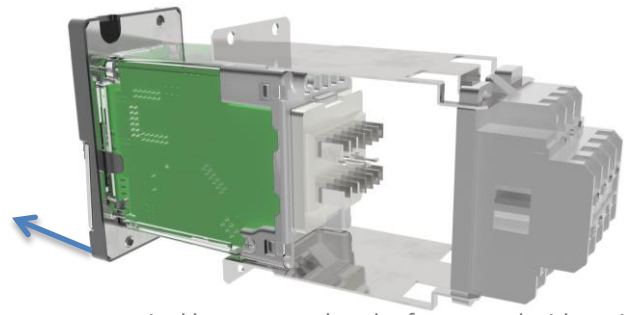

Rear connect terminal base secured to the front panel with optional retention plates - TBD-R2. Relay shown partially drawn-out of the panel.

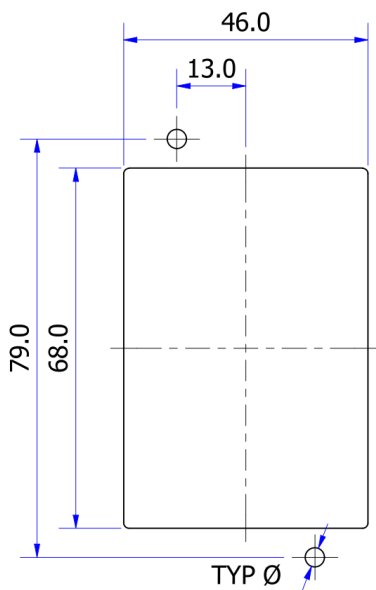

TABLE 1 - HOLE DIA	
PANEL THICKNESS (T)	HOLE DIA (Ø)
1mm < T < 2mm	3.6mm
T > 2mm	3.7mm

Panel cut-out to flush mount relay for use with rear connect TBD-R1 base

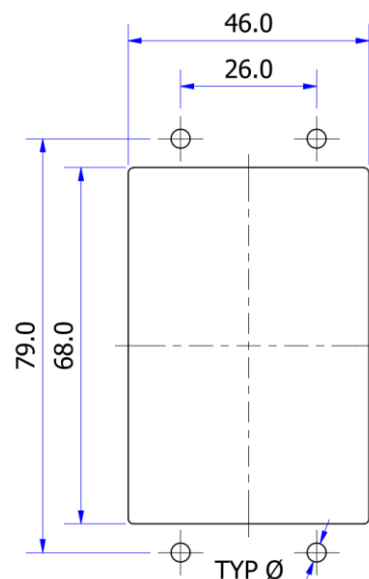

TABLE 1 - HOLE DIA	
PANEL THICKNESS (T)	HOLE DIA (Ø)
1mm < T < 2mm	3.6mm
T > 2mm	3.7mm

Panel cut-out to flush mount relay for use with rear connect TBD-R2 base

## Delta 1S27 Relay Order Codes

1S27 -		[ ]	[ ]	[ ]	[ ]	[ ]	[ ]	
Arc Sensor Inputs	A						Point sensor inputs only	
	B						Point sensor inputs + Optic fibre linear sensor input	
Future Use	-						None	
Auxiliary Supply	F						19-85 V DC or 19-65V AC	
	G						45-165 V DC or 40-150V AC	
	H						125-250V DC or 95-240 V AC	
Mounting Configuration	A						Surface or rail mounting without terminal block	
	A-F						Surface or rail mounting including TBD-F terminal block	
	A-R1						Surface mount including TBD-R1 terminal block	
	B						Panel mounting without terminal block	
	B-R1						Panel mounting including TBD-R1 terminal block	
	B-R2						Panel mounting including TBD-R2 terminal block**note 2	
Software Options						-	Not required	
Hardware Options							-	Not required

**#** Refer note 1

NOTE 1 The Delta relay will be supplied for mounting as per the order code selection above. However, the relay mounting can be changed by the customer from DIN rail mount (Code A) to Panel Mount (Code B) or vice versa using the TBD-AC Relay Mount Conversion Kit. This provides more flexibility for the customer to manage changes at site without returning to the factory for modification. The front panel relay ID employs a # code in place of the mounting configuration code to indicate that either mounting configuration is possible. For example, 1S27-A-G#  
 The mounting configuration code **A** or **B** is shown on the escutcheon moulding.

\*\*NOTE 2 The TBD-R2 retention plates cannot be used when the 1S27-B optic fibre linear sensor input is utilised.

## Delta Terminal Block Order Codes

TBD -		[ ]
Terminal Block Connection	F	Front connect
	R1	Rear connect
	R2	Rear connect using terminal block retention plates

## Delta Accessories

Relay mount components	TBD-AC	Relay mount conversion kit (Excludes terminal block)
Panel mount frames	TBD-AD	Dual - 4U x 2U frame to rack mount 2 high x 1 wide Delta relays
	TBD-AQ	Quad - 4U x 4U frame to rack mount 2 high x 2 wide Delta relays



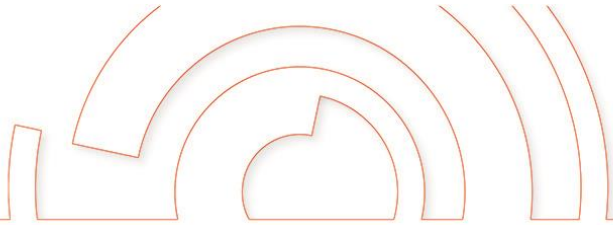

**RMS Mors Smitt**  
A *Wabtec* Company

---

**RMS Mors Smitt**  
19 Southern Court  
Keysborough, VIC 3173, Australia  
Tel: +61 (0)3 8544 1200  
sales.rms@wabtec.com



**RMS Mors Smitt**  
A *Wabtec* Company

**Wabtec Netherlands B.V.**  
Darwinstraat 10  
6718 XR Ede, Netherlands  
Tel: +31 (0)88 600 4500  
sales.msbv@wabtec.com



Visit [www.morssmitt.com/rms](http://www.morssmitt.com/rms) for the latest product information.  
Due to RMS continuous product improvement policy this information is subject to change without notice

