





Arc Fault Protection System

1S23 Arc Flash Timing Test Guide

relay monitoring systems pty ltd

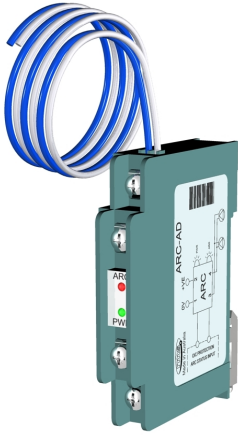
Advanced Protection Devices

		
<p>RMS 1S30 Optical Arc Fault Sensor</p>	<p>RMS 1S23 Arc Fault Module 1 or 2 sensor versions</p>	<p>External Overcurrent Relay with Current Check as required</p>
		
<p>YN-560 flash light</p>	<p>LS-PC635 Sync cable and 6.35mm Mono Line socket</p>	<p>Manual mode, 25% of power (binary coding)</p>

Contents

1.0	Introduction	3
2.0	Reference Documents	3
2.1	Expected timing performance	3
3.0	Method	4
3.1	Equipment Under Test	4
3.2	Recommended Test Equipment	4
3.3	Flash Setting	4
3.4	Safety precautions	4
3.5	Timing test of 1S23 ARC Trip Output	5
3.6	Timing test of 1S23 (using current check in overcurrent relay)	7
4.0	Results	8
4.1	Results of 1S23 Output only testing	8
4.2	Results of 1S23 testing including Overcurrent Relay Output (with current checking)	8

The copyright and other intellectual property rights in this document and in any model or article produced from it (and including any Registered or unregistered design rights) are the property of Relay Monitoring Systems Pty Ltd. No part of this document shall be reproduced or modified or stored in another form, in any data retrieval system, without the permission of Relay Monitoring Systems Pty Ltd, nor shall any model or article be reproduced from this document without consent from Relay Monitoring Systems Pty Ltd.

While the information and guidance given in this document is believed to be correct, no liability shall be accepted for any loss or damage caused by any error or omission, whether such error or omission is the result of negligence or any other cause. Any and all such liability is disclaimed.

© Relay Monitoring Systems Pty Ltd 2001-2012
6 Anzed Court • Mulgrave 3170 • AUSTRALIA
Phone 61 3 8544 1200 • Fax 61 3 8544 1201
Email rms@rmspl.com.au • Web www.rmspl.com.au

To download the Arc Flash Timing Test Guide:
http://www.rmspl.com.au/userguide/1s23_Arc_Timing_user_guide.pdf

1.0 Introduction

This Test Guide describes the method for testing the timing performance of the 1S23 Arc Protection System comprising of Arc Sensors and Arc Fault Module. The simple test setup uses an off the shelf photo flash and standard Doble (or equivalent) test set.

For Arc simulation an off the shelf photo flash such as the Yongnuo (YN-560) or similar may be utilised. This flash needs to be equipped with a PC Sync input, for flash initiation, and a Guide Number specification of at least 58 m to ensure reliable sensor operation.

Flash initiation and protection timings are undertaken using an AC Test System such as the Doble F2250 (F2251) or similar. An AC channel in the test set is utilised in Arc Fault Applications employing current checking.

2.0 Reference Documents

Table 1

Description	Document ID	Comment
RMS Technical Bulletin	1S30	Issue G, 18/07/2011
RMS Technical Bulletin	1S23	Issue G, 6/06/2012
Photo Flash Technical Manual	YN-560	Yongnuo
PC Sync to 6.35mm Cable	LS-PC635	www.hkyongnuo.com

2.1 Expected timing performance

- The Arc Fault System Module output (1S30 + 1S23) shall have a total operate time of less than 2 ms.
- The Arc Fault System without an over current check (1S30 + 1S23 + External Overcurrent Relay) shall have a total trip time of less than 15 ms.
- The Arc Fault System with an external over current check (1S30 + 1S23 + External Overcurrent Relay with current check) shall have a total trip time of less than 30 ms at 5x current setting.

3.0 Method

3.1 Equipment Under Test

RMS 1S30 - Optical Arc Fault Sensor,

RMS Arc Fault Monitors 1S23

External Overcurrent Relay (example Reyrolle Argus C 7SR1206)

3.2 Recommended Test Equipment

- AC Test System "Doble" F2250 (F2251) or similar
- Auxiliary Power supply 40-150 VDC, 1A
- Photo Flash YN-560, Guide number 58 m (@ ISO 100, 105 mm), 4xAA batteries
- Yongnuo PC Sync to 6.35 mm Cable, LS-PC635
- 6.35 mm Mono Socket, cable type, terminated with banana plugs on the ends for connection to test set

3.3 Flash Setting

To ensure positive operation of the Arc Fault sensors for testing purposes the Photo Flash unit must be set to emit a flash of suitable intensity at a given distance. The angle of incidence of the flash with respect to the sensing point will also influence operation of the Arc Fault sensor, the test flash is to be placed in front of the sensor and aimed directly at the sensor point as shown below:

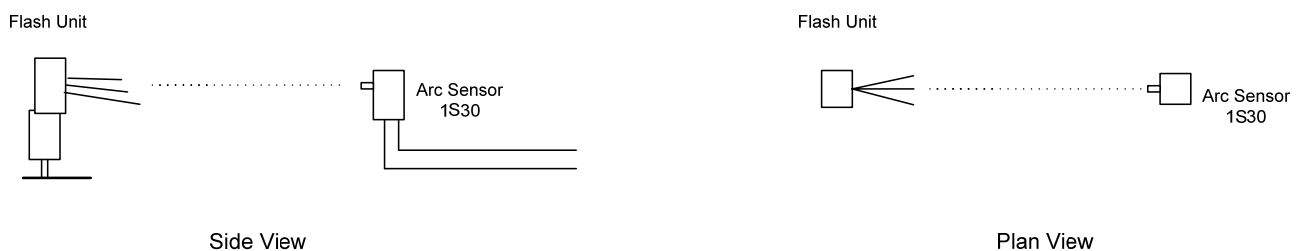

For up to 1m flash distance set the YN-560 Photo Flash at 25% power.

For up to 3m flash distance set the YN-560 Photo Flash at 100% power.

For other photo flash units experimentation with photo flash setting may be required to achieve positive operation of the Arc Fault sensor.

3.4 Safety precautions

To prevent eye injury avoid flash exposure at close proximity.

Provide a warning to others to shield their eyes prior to a test sequence.

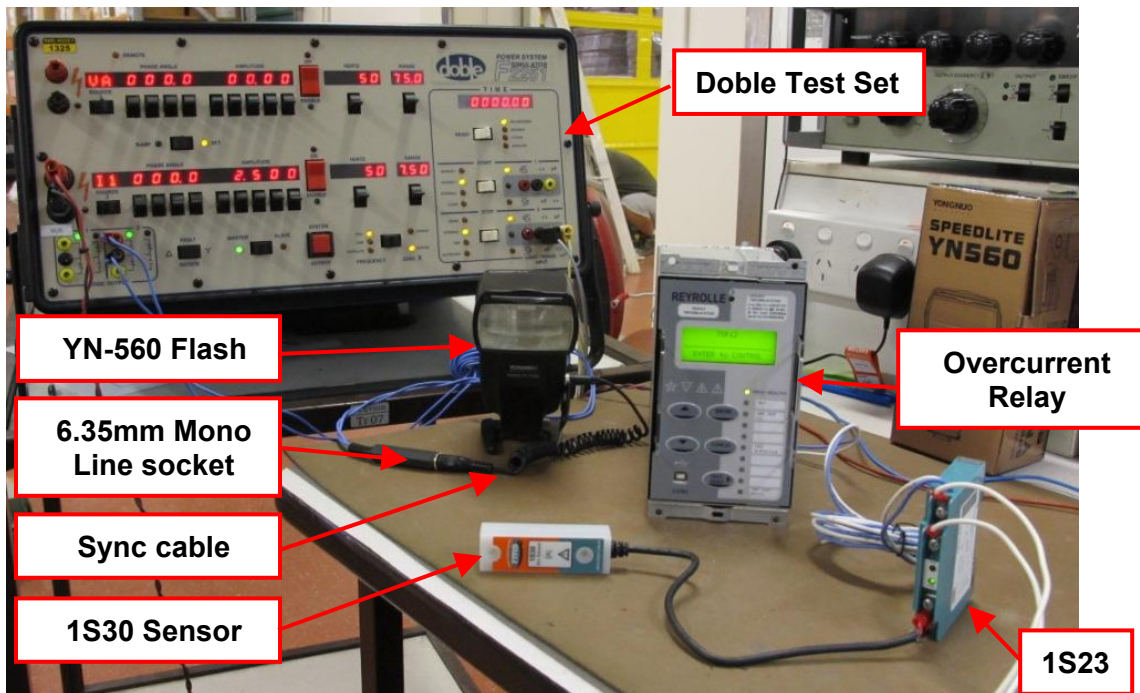

Figure 2: 1S23 setup - general view

3.5.2 Test procedure:

1. Set up the test as shown in the Figure 1. Example shows testing for single sensor operation.
2. On the Doble system set the output of Channel 2 to 0 A/ 50 Hz.
3. Set timer Start to "Source 2".
4. Set timer Stop to "External" and connect for voltage sensing for transition from voltage high to voltage low. Reset the timer.
5. Switch on the Photo Flash unit and wait until the unit is ready to discharge.
6. Enable the output of Channel 2 (green LED shall be lit). To start the test press the Red button "Initiate".
7. The Photo Flash will operate and the Doble timer will start counting. Upon closure of the 1S23 output the timer will stop counting.
8. Read the timer result.
9. Repeat the test at least 3 times. Record results in the results table.
10. Repeat tests for all zones and record timing results of respective zone outputs.

3.6 Timing test of 1S23 (using current check in overcurrent relay)

3.6.1 Example Test setup

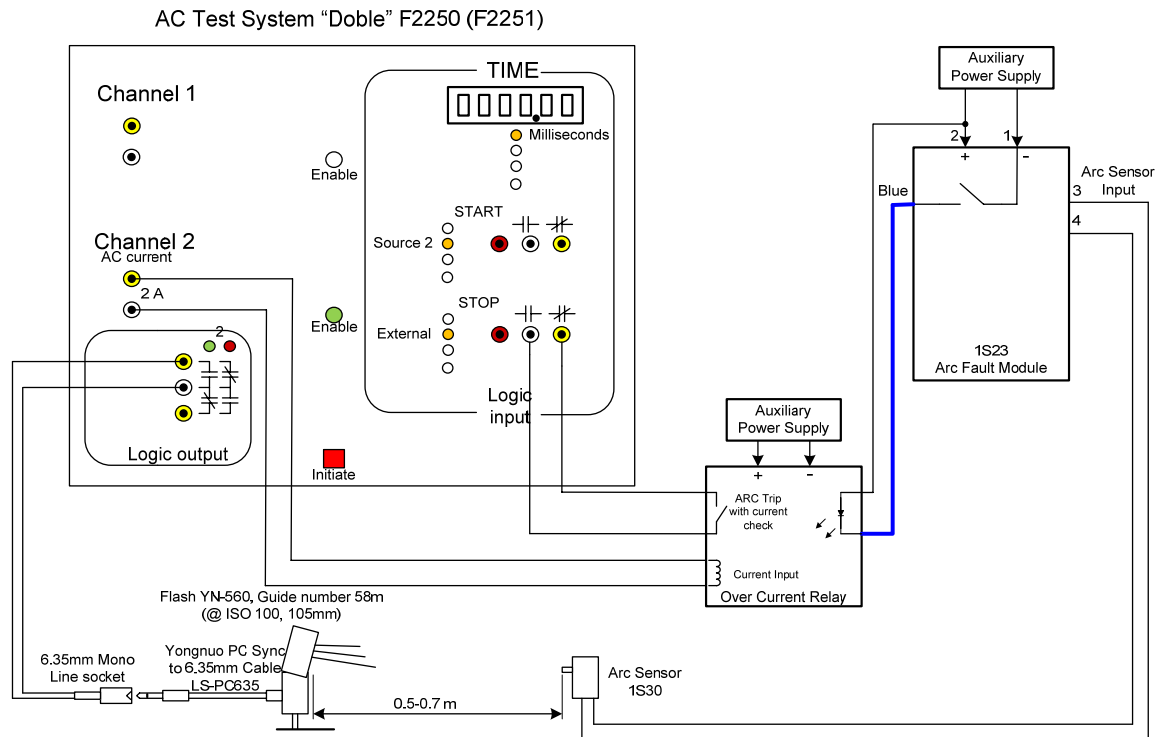

Figure 3: 1S23 (using current check in overcurrent relay) test setup

(Example shows 1S23 and 1 sensor under test connected to Status input of an Overcurrent relay and Arc Trip with Current check output being monitored for timing purposes)

3.6.2 Test procedure:

1. Set up the test as shown in Figure 3. Example shows testing for single sensor operation.
2. Set Input current setting of the external current check relay to the required current sensitivity.
3. On the Doble system set the output of Channel 2 to 5x current setting of the current check relay, for example for a relay set for 0.5A secondary operation set the Doble to output 2.5A/ 50 Hz.
4. Set timer Start to "Source 2".
5. Set timer Stop to "External" and connect for clean contact transition from open to closed. Reset the timer.
6. Switch on the Photo Flash unit and wait until the unit is ready to discharge.
7. Enable the output of Channel 2 (green LED shall be lit). To start the test press the Red button "Initiate".
8. The Photo Flash will operate and the Doble timer will start counting. Upon the closing of the overcurrent relay output contacts the timer will stop counting.
9. Read the timer result.
10. Repeat the test at least 3 times. Record results in the results table.
11. Disable Channel 2 of the Doble system after each test to avoid the potential of thermally overloading the current input of the Current Check Relay.
12. Repeat the test for all phases.

4.0 Results

Test results may be recorded in the tables below.

4.1 Results of 1S23 Output only testing

Table 2

Description	Distance, cm	Delay, ms	Expected	Pass /Fail
Test 1			≤2 ms	
Test 2			≤2 ms	
Test 3			≤2 ms	
Overall result			≤2 ms	

4.2 Results of 1S23 testing including Overcurrent Relay Output (with current checking)

Table 3

Description	Distance, cm	Delay, ms	Expected	Pass /Fail
Test 1			≤30 ms	
Test 2			≤30 ms	
Test 3			≤30 ms	
Overall result			≤30 ms	

Australian Content

Unless otherwise stated the product(s) quoted are manufactured by RMS at our production facility in Melbourne Australia. Approximately 60% of our sales volume is derived from equipment manufactured in house with a local content close to 80%. Imported components such as semi-conductors are sourced from local suppliers & preference is given for reasonable stock holding to support our build requirements.

Quality Assurance

RMS holds NCSI (NATA Certification Services International), registration number 6869 for the certification of a quality assurance system to AS/NZS ISO9001-2008. Quality plans for all products involve 100% inspection and testing carried out before despatch. Further details on specific test plans, quality policy & procedures may be found in section A4 of the RMS product catalogue.

Product Packaging

Protection relays are supplied in secure individual packing cardboard boxes with moulded styrene inserts suitable for recycling. Each product & packing box is labeled with the product part number, customer name & order details.

Design References

The products & components produced by RMS are based on many years of field experience since Relays Pty Ltd was formed in 1955. A large population of equipment is in service throughout Australia, New Zealand, South Africa, The Middle East & South East Asia attesting to this fact. Specific product & customer reference sites may be provided on application.

Product Warranty

All utility grade protection & auxiliary relay products, unless otherwise stated, are warranted for a period of 24 months from shipment for materials & labour on a return to factory basis. Repair of products damaged through poor application or circumstances outside the product ratings will be carried out at the customer's expense.

Standard Conditions of Sale

Unless otherwise agreed RMS Standard Terms & Conditions (QF 907) shall apply to all sales. These are available on request or from our web site.



Relay Monitoring Systems Pty Ltd

6 Anzed Court, Mulgrave, Victoria 3170, AUSTRALIA

Tel: +61 3 8544 1200 Fax: +61 3 8544 1201 Email: rms@rmspl.com.au Web: www.rmspl.com.au